



# Treatment Technology Review and Assessment

Association of Washington Business

Association of Washington Cities

Washington State Association of Counties

May 24, 2022

*This page is intentionally left blank.*



## Table of Contents

Executive Summary .....	1
1 Introduction.....	8
2 Derivation of the Baseline Study Conditions and Rationale for Selection of Effluent Limitations .....	11
2.1 Background .....	11
2.2 Assumptions Supporting Selected Ambient Water Quality Criteria and Effluent Limitations .....	12
2.2.1 Mercury .....	16
2.3 Analytical Methods .....	18
3 Wastewater Characterization Description .....	22
3.1 Summary of Wastewater Characterization.....	22
3.2 Baseline Wastewater Treatment Facility.....	22
3.3 Toxic Constituents.....	23
4 Treatment Approaches and Costs .....	24
4.1 Constituent Removal – Literature Review.....	24
4.1.1 Arsenic .....	24
4.1.2 Polycyclic Aromatic Hydrocarbons - Benzo(a)pyrene.....	29
4.1.3 Mercury .....	31
4.1.4 Polychlorinated Biphenyls .....	34
4.2 Unit Processes Evaluated .....	36
4.3 Unit Processes Selected .....	41
4.3.1 Baseline Treatment Process .....	44
4.3.2 Advanced Treatment – Tertiary UF/RO .....	46
4.3.3 Advanced Treatment – Tertiary UF/GAC Alternative .....	52
4.3.4 Advanced Treatment – Tertiary UF/AOP/GAC .....	56
4.3.5 Advanced Treatment – Tertiary UF/AOP/GAC/RO.....	58
4.4 Steady-State Mass Balance.....	60
4.5 Adverse Environmental Impacts Associated with Advanced Treatment Technologies .....	61
4.6 Costs .....	65
4.6.1 Approach .....	65
4.6.2 Unit Cost Values.....	66
4.6.3 Net Present Value of Total Project Costs and Operations and Maintenance Cost in 2022 Dollars .....	68
4.6.4 Unit Cost Assessment.....	70
4.7 Pollutant Mass Removal.....	78
4.8 Sensitivity Analysis.....	79
5 Summary and Conclusions .....	80
6 References .....	83
7 Appendices.....	90



## List of Tables

Table 2-1. Summary of Effluent Discharge Toxics Limits .....	15
Table 2-2. Washington’s Water Quality Standards for Mercury.....	16
Table 2-3. Proposed Methylmercury Human Health Criteria for Washington.....	17
Table 2-4. CFR Part 136 List of Approved Inorganic Test Procedures .....	18
Table 2-5. CFR Part 136 List of Approved Test Procedures for Non-Pesticide Organic Compounds.....	19
Table 2-6. Summary of Analytical Laboratory Techniques Standard Levels.....	20
Table 2-7. Currently Not Approved Analytical Methods Pending Future Decisions .....	21
Table 2-8. Comparison of Analytical Laboratory Techniques Standard Levels and Water Quality Standards.....	21
Table 3-1. General Wastewater Treatment Facility Characteristics .....	22
Table 4-1. Summary of Arsenic Removal Technologies <sup>1</sup> .....	25
Table 4-2. Contaminants Removal Breakdown by Individual Unit Process.....	39
Table 4-3. Unit Processes Description for Each Alternative .....	43
Table 4-4. Brine Disposal Method Relative Cost Comparison.....	49
Table 4-5. Energy Breakdown for Each Alternative (5 mgd design flow) .....	63
Table 4-6. Economic Evaluation Variables .....	67
Table 4-7. Treatment Technology Total Project Costs in 2022 Dollars for a 5 mgd Facility .....	68
Table 4-8. Treatment Technology Total Project Costs in 2022 Dollars for a 0.5 mgd Facility .....	74
Table 4-9. Treatment Technology Total Project Costs in 2022 Dollars for a 25 mgd Facility .....	75
Table 4-10. Pollutant Mass Removal by Contaminant for a 5 mgd Facility .....	78
Table 4-11. Unit Cost by Contaminant for a 5 mgd Facility Implementing Advanced Treatment using UF/RO .....	79

## List of Figures

### List of Appendices

Appendix A. Unit Process Sizing Criteria.....	A-1
Appendix B. Greenhouse Gas Emissions Calculation Assumptions .....	B-1

## Acronyms

Acronym	Definition
AACE	Association for the Advancement of Cost Engineering
AOP	advanced oxidation processes
AWB	Association of Washington Businesses
BAC	biological activated carbon
BAP	benzo(a)pyrene
BRS	Brine Recovery System
BOD	biochemical oxygen demand
BTU	British thermal unit
CEPT	Chemically-enhanced primary treatment
cf	cubic feet
CIP	clean in place
CNT	carbon nanotubes (CNTs)
CRITFC	Columbia River Inter-Tribal Fish Commission
Ecology	Washington Department of Ecology
EPA	U.S. Environmental Protection Agency
FCR	fish consumption rate
g/day	grams per day
GAC	granular activated carbon
gal	gallon
gfd	gallons per square foot per day
GHG	greenhouse gas
gpd	gallons per day
gpm	gallons per minute
GWh	giga watt hours
HDR	HDR Engineering, Inc.
HHWQC	human health water quality criteria
HRT	hydraulic residence time
IPCC	Intergovernmental Panel on Climate Change
kg	kilogram
kWh/MG	kilowatt-hours per million gallons
lb	pound
MBR	membrane bioreactor
MCL	maximum contaminant level
MF	microfiltration
mgd	million gallons per day
mg/L	milligrams per liter
MMBTU	million British thermal units
MWh/d	megawatt-hours per day
NF	nanofiltration
ng/L	nanograms per liter
NPDES	National Pollutant Discharge Elimination System
NPV	net present value
O&M	operations and maintenance
ODEQ	Oregon Department of Environmental Quality
PAC	powdered activated carbon
PAH	polycyclic aromatic hydrocarbons
PCB	polychlorinated biphenyls
PE	population equivalents
PIX	potable ion exchange
ppm	parts per million



<b>Acronym</b>	<b>Definition</b>
RO	reverse osmosis
SDWA	Safe Drinking Water Act
sf	square feet
SGSP	salinity gradient solar pond
SRT	solids retention time
Study Partners	Association of Washington Business/Association of Washington Cities and Washington State Association of Counties consortium
TDS	total dissolved solids
TMDL	total maximum daily load
TSS	total suspended solids
UF	ultrafiltration
µg/L	micrograms per liter
USDA	U.S. Department of Agriculture
UV	ultraviolet
WAC	Washington Administrative Code
WAS	waste activated sludge
WLA	waste load allocation
WWTP	wastewater treatment plant
ZLD	zero liquid discharge



*This page is intentionally left blank.*





# Executive Summary

This study evaluated treatment technologies potentially capable of meeting the U.S. Environmental Protection Agency (EPA) proposed human health water quality criteria (HHWQC) for the state of Washington (87 FR 19046, April 1, 2022). Through several Clean Water Act regulatory programs, promulgated water quality criteria influence the establishment of effluent limits in NPDES permits. HDR Engineering, Inc. (HDR) completed a literature review of potential technologies and an engineering review of the capabilities of those technologies to evaluate and screen candidate treatment methods for four pollutants: arsenic, benzo(a)pyrene (BAP), mercury, and polychlorinated biphenyls (PCBs). Four advanced treatment process trains were selected as alternatives to compare against an assumed existing baseline secondary treatment system commonly employed by industrial and municipal dischargers. These four alternatives included enhanced secondary treatment with ultrafiltration/reverse osmosis (UF/RO) and enhanced secondary treatment with ultrafiltration/granulated activated carbon (UF/GAC). Two additional alternatives included an advanced oxidation process (AOP) in a UF/AOP/GAC system and a UF/AOP/GAC/RO system to achieve additional pollutant removal. HDR developed capital costs, operating costs, and a net present value (NPV) for each alternative, including the incremental cost to implement improvements for an existing secondary treatment facility.

Currently, there are no known commercial, industrial, or municipal facilities that treat to the low concentration levels of the proposed HHWQC and anticipated effluent limits that are under consideration. Based on the literature review, research, effluent monitoring reports, and reports from bench scale studies, the following conclusions can be made from this study:

- Revised HHWQC based on EPA's proposed Human Health Criteria for Washington (Federal Register 2022) will result in very low water quality criteria for toxic constituents.
- There are limited "proven" technologies available for NPDES permittees to meet required effluent quality limits that would be derived from revised HHWQC.
  - Current secondary wastewater treatment facilities provide high degrees of removal for toxic constituents; however, they are not capable of compliance with water quality-based National Pollutant Discharge Elimination System (NPDES) permit effluent limits derived from the proposed HHWQC.
  - Advanced treatment technologies have been investigated and candidate process trains have been conceptualized for toxics removal.
    - Advanced wastewater treatment technologies may enhance toxics removal rates; however, they will not be capable of achieving an effluent limit at the level of EPA's proposed HHWQC for total PCB of 7E-06 ug/l (water and organisms). The lowest levels achieved based on the literature review were between

<0.00001 and 0.0002 µg/L, two orders-of-magnitude greater than the proposed HHWQC of 0.000007 µg/L.

- Achieving an effluent concentration at the current HHWQC for inorganic arsenic of 0.018 µg/L (water and organism) is questionable, even for the most elaborate treatment process trains, because little performance data is available from facilities operating at these low concentrations. Most treatment technology performance information available in the literature is based on drinking water treatment applications targeting a much higher Safe Drinking Water Act (SDWA) Maximum Contaminant Level (MCL) of 10 µg/L. Data from a confidential demonstration project using UF/RO/AOP shows performance to the same order-of-magnitude at <0.036 µg/L versus the-HHWQC 0.018 µg/L. It is possible this demonstration project is producing effluent near the proposed HHWQC for inorganic arsenic, however data to evaluate full technical and economic feasibility for this demonstration project was not available.
    - The existing HHWQC for mercury is a fish tissue-based limit of 0.3 mg/kg (organism only). Science-based and site-specific factors must be employed to convert this tissue-based limit to a water column concentration. The range of potential water column concentrations for methylmercury associated with EPA’s 0.03 mg/kg fish tissue concentration are lower than the approved analytical methods in 40 CFR part 136 for Method 1631E with a quantitation level of 0.0005 µg/L. Consequently, treatment facilities would need to target non-detectable levels of effluent mercury less than 0.0005 µg/L. Achieving this concentration for mercury in effluent appears unlikely.
    - Achieving an effluent concentration at the EPA proposed HHWQC for Benzo(a) Pyrene of 1.6E-05 µg/l (water and organism) appears unlikely. Little information is available to assess the potential for advanced technologies to treat to this concentration. A municipal wastewater treatment plant study, showing the apparent technical limits of treatment capability, reported both influent and effluent BAP concentrations of <0.0057 µg/L, two orders-of-magnitude greater than the proposed HHWQC of 0.000016 µg/L (Ecology, 2010).
- Some technologies may be effective at treating identified pollutants of concern to achieve the full suite of EPA’s proposed HHWQC, while others may not. It is therefore even more challenging to identify a technology that can meet all constituent limits simultaneously. Multiple technologies paired together may be necessary, further exacerbating the issue of economic feasibility.
- Implementation of additional treatment will result in additional collateral impacts including:

- High energy consumption.
  - Increased air pollution emissions, including for greenhouse gas emissions, which may trigger environmental permitting obligations under the Clean Air Act.
  - Increased solids production from chemical addition. Additionally, the membrane and GAC facilities will capture more solids that require processing and utilization or disposal.
  - Increased physical space requirements at treatment plant sites for advanced treatment facilities and residuals management, including reverse osmosis reject brine processing.
  - Any facility expansion may trigger consideration of environmental justice impacts on Overburdened Communities and challenge land use permitting decision-making.
- The recognition that advanced treatment technology alone would not be capable of achieving water quality-based effluent limits resulting from the proposed HHWQC will force reliance on other regulatory tools in NPDES permitting to provide a compliance pathway. These tools might include long-term variances or compliance schedules, will be controversial, and undertaken with high transactions costs and uncertainty.
  - Advanced treatment processes incur very significant capital construction and operating costs. Table ES-1 presents a summary range of these costs for the baseline secondary treatment, plus the and increment of additional costs for the advanced treatment technologies. The table is delineated by alternative, whereby each advanced treatment technology includes separate line items for the baseline cost, as well as the additional incremental cost to add advanced treatment technologies to the baseline and the total cost (sum of baseline and advanced treatment technologies). The table indicates that the unit NPV cost for baseline conventional secondary treatment ranges from \$16 to \$39 per gallon per day of treatment capacity. The unit cost for the advanced treatment alternatives increases the range from the low \$30s to \$120 on a per gallon per-day of treatment capacity. The resulting unit cost for improving from secondary treatment to advanced treatment ranges between \$15 and \$81 per gallon per day of treatment capacity. Unit costs were also evaluated for both a 0.5 and 25 mgd facility. The range of unit costs for improving a 0.5 mgd from secondary to advanced treatment is \$31 to \$168 per gallon per day of treatment capacity. The range of unit costs for improving a 25 mgd from secondary to advanced treatment is \$18 to \$74 per gallon per day of treatment capacity.

**Table ES-1. Treatment Technology Costs for Baseline Secondary Treatment and Advanced Treatment Alternatives in 2022 Dollars for a 5-mgd Facility**

Alternative	Total Construction Cost (\$ Million)	O&M Net Present Value, (\$ Million)**	Total Net Present Value, (\$ Million)	NPV Unit Cost, (\$/gpd)
Baseline (Conventional Secondary Treatment)	72 - 178	8 - 19	80 - 197	16 - 39
Advanced Treatment - UF/RO*				
Baseline (from the top of the table)	72 - 178	8 - 19	80 - 197	16 - 39
Additional Cost (beyond Baseline) for UF/RO*from Baseline	75 - 185	21 - 51	96 - 237	19 - 47
Total Cost (includes Baseline): Advanced Treatment - UF/RO*	148 - 364	29 - 70	176 - 434	35 - 87
Advanced Treatment - UF/GAC				
Baseline (from the top of the table)	72 - 178	8 - 19	80 - 197	16 - 39
Additional Cost (beyond Baseline) for UF/GAC	52 - 128	22 - 54	74 - 182	15 - 36
Total Cost (includes Baseline): Advanced Treatment - UF/GAC	125 - 307	29 - 72	154 - 379	31 - 76
Advanced Treatment - UF/AOP/GAC				
Baseline (from the top of the table)	72 - 178	8 - 19	80 - 197	16 - 39
Additional Cost (beyond Baseline) for UF/AOP/GAC	66 - 162	31 - 76	97 - 239	19 - 48



Alternative	Total Construction Cost (\$ Million)	O&M Net Present Value, (\$ Million)**	Total Net Present Value, (\$ Million)	NPV Unit Cost, (\$/gpd)
Total Cost (includes Baseline): Advanced Treatment - UF/AOP/GAC	138 - 340	39 - 95	177 - 435	35 - 87
Advanced Treatment - UF/AOP/GAC/RO*				
Baseline (from the top of the table)	72 - 178	8 - 19	80 - 197	16 - 39
Additional Cost (beyond Baseline) for UF/AOP/GAC/RO*	117 - 289	47 - 116	164 - 405	33 - 81
Total Cost (includes Baseline): Advanced Treatment - UF/AOP/GAC/RO*	190 - 467	55 - 135	244 - 602	49 - 120

\*Assumes BRS for RO brine management, followed by evaporation ponds. Other options are available as listed in Section 4.3.2

\*\*Includes the cost for labor.

mgd=million gallons per day

MG=million gallons

MF/RO=membrane filtration/reverse osmosis

MF/GAC=membrane filtration/granulated activated carbon

O&M=operations and maintenance

Net Present Value = total financed cost assuming a 5 percent nominal discount rate over an assumed 20-year equipment life.

Costs presented above are based on a treatment capacity of 5.0 mgd, however, existing treatment facilities range dramatically across Washington in size and flow treated. The key differences in cost between the baseline and the advanced treatment alternatives are as follows:

- Larger aeration basins than the baseline to account for the longer solids retention time (SRT) in activated sludge systems (>8 days for advanced treatment versus <4 days baseline secondary treatment).
- Additional pumping stations to pass water through the membrane facilities and granulated activated carbon facilities. These are based on maximum month flows because an equalization basin was incorporated.
- Membrane facilities (equipment, tanks chemical feed facilities, pumping, etc.) and replacement membrane equipment.
- Granulated activated carbon facilities (equipment, contact tanks, pumping, granulated activated carbon media, etc.)

- Additional energy and chemical demand to operate the membrane and granulated activated carbon facilities
- Additional energy to feed and backwash the granulated activated carbon facilities.
- Brine Recovery System facilities to further concentrate the brine reject. Brine Recovery System facilities are energy/chemically intensive and they require membrane replacement every few years due to the brine reject water quality.
- Membrane and granulated activated carbon media replacement represent a significant operation and maintenance cost.
- Additional hauling and fees for new and disposal of spent granulated activated carbon off-site.
- Advanced oxidation process costs to break down BAP and PCBs for increased removal efficiency.

The mass of pollutant removal by implementing advanced treatment was calculated based on reducing current secondary effluent discharges to revised effluent limits for the four pollutants of concern. These results are provided in Table ES-2 as well as a median estimated unit cost basis for the mass of pollutants removed.

**Table ES-2. Unit Cost by Contaminant for a 5-mgd Facility Implementing Advanced Treatment using Ultrafiltration/Reverse Osmosis**

Component	Arsenic	BAPs	Mercury	PCBs
Required HHWQC based Effluent Quality (µg/L)	0.018	0.000016	0.0005	0.000007
Current Secondary Effluent Concentration (µg/L)	5	0.006	0.025	0.002
Total Mass Removed (lb) over 20-year Period	1517	1.82	7.5	0.61
Median Estimated Unit Cost (NPV per total mass removed in pounds over 20 years)	\$201,000	\$170,000,000	\$41,000,000	\$500,000,000
µg/L=micrograms per liter lb=pounds NPV=net present value				

Collateral adverse environmental impacts associated with implementing advanced treatment were evaluated. The key impacts from this evaluation include increased energy use, greenhouse gas production, land requirements and treatment residuals disposal. Operation of advanced treatment technologies could increase electrical energy by a factor of approximately 2 to 3 times over the baseline secondary treatment system. Direct and indirect greenhouse gas emission increases are related to the operation of advanced treatment technologies and electrical power sourcing, with increases of at least 50 to 100 percent above the baseline secondary treatment system. It is worthwhile

noting that residual materials from treatment, such as RO reject brine and spent carbon sorption media, may potentially be hazardous wastes and their disposal may be challenging to permit and implement.



# 1 Introduction

The purpose of this assessment is to update the 2013 Treatment Technology Review and Assessment (HDR 2013) that was prepared to analyze the technical feasibility and capital and operating costs of wastewater treatment technologies to address proposed Human Health-Based Water Quality Criteria (HHWQC). These proposed revisions of Washington's surface water quality standards regulation, WAC 173-201A, resulted from a multi-year public engagement activity led by the Department of Ecology. The state of Washington adopted this rule package in August 2015. The proposed criteria were considered to be the most stringent set of toxic pollutant standards in the United States and there were concerns about the ability of NPDES permittees to comply with Clean Water Act regulatory programs based on those criteria. A coalition of industrial and municipal NPDES permittees sponsored the HDR technology and cost assessment.

A tortuous administrative process was then set into motion. The Environmental Protection Agency responded by partially approving and partially disapproving Washington's adopted rule in a November 2016 Federal Register notice. In that notice the EPA alleged that disapproved criteria were not scientifically defensible and thus not protective of Washington's designated water uses. In the late 2016 notice, the EPA proposed and subsequently adopted a more stringent set of HHWQC based on re-consideration of tribal fish consumption, the incremental cancer risk level, and other input factors germane to the derivation of numeric criteria. A 2017 industry petition to the EPA requested a reconsideration of the partial disapproval determination and repeal of the November 2016 HHWQC. EPA granted this petition in May 2019, which then had the effect of returning Washington's HHWQC to the set adopted by the state in August 2015. The state of Washington, certain Indian tribes, and various environmental groups followed with a legal challenge of this EPA decision. These parties requested and the jurisdictional federal district court agreed to hold any legal proceedings in abeyance while EPA reconsidered its 2019 decision. In an April 1, 2022 Federal Register notice, the EPA has now proposed for adoption the HHWQC promulgated in November 2016. It is this set of more stringent numeric criteria that the Study Partners of this 2022 HDR technology and cost assessment is based on.

Water quality criteria serve as the foundation for the implementation of many Clean Water Act regulatory programs. For example, waterbodies not consistently achieving criteria are designated as such in the Clean Water Act Section 303(d) list of impaired waters. This listing triggers an obligation for the development of a total maximum daily load (TMDL) or water cleanup plan, designed to reduce loadings of the listed pollutant into the waterbody to ultimately lead to achievement of the standard. NPDES permittees contributing the listed pollutant are given a waste load allocation or "water quality-based effluent limits" set at concentrations equal to or below the water quality numeric criterion. The permittee may lose access to any "mixing zone." The Sections 303(d) listing may be based on either water column concentrations or fish tissue concentrations for pollutants which bioaccumulate. In waterbodies attaining the respective water quality criterion, a "reasonable potential analysis" is completed as an element of an NPDES permitting exercise to determine if a pollutant discharge could "cause or contribute" to the

exceedance of a water quality numeric criterion or anti-degradation requirement. Either of these permitting requirements can serve as a basis for establishing permittee effluent limits. The presumption is that more stringent HHWQC will, in time, drive lower effluent limits. A companion presumption holds that as EPA-approved analytical methods become more sensitive and/or as jurisdictional agencies more intensely evaluate ambient waterbodies or choose to monitor pollutants concentrations in fish tissues, the prevalence of “non-achievement” of HHWQC will increase.

The Study Partners in a collaboration of the Association of Washington Business, Association of Washington Cities, and Washington State Association of Counties, hold NPDES permits authorizing wastewater discharges. The prospect of more stringent HHWQC, and the resulting needs for advanced treatment technologies to achieve lower effluent discharge limits, has led this consortium to sponsor a study to assess technology availability and capability, capital and operations and maintenance (O&M) costs, pollutant removal effectiveness, and collateral environmental impacts of candidate technologies.

The “base case” for the study began with the identification of four nearly ubiquitous toxic pollutants present in many industrial and municipal wastewater discharges, and the specification of pollutant concentrations in well-treated secondary effluent. The pollutants are arsenic, benzo(a)pyrene (BAP), mercury, and polychlorinated biphenyls (PCBs), which were selected for review based on available monitoring data and abundant presence in the environment. The purpose of this study is to review the potential water quality standards and associated treatment technologies able to meet those standards for four pollutants.

Established and industry accepted wastewater treatment processes and wastewater characteristics were used as the common baseline for comparison with all of the potential future treatment technologies considered. An existing secondary treatment process with disinfection at a flow of 5 million gallons per day (mgd) was used to represent existing conditions. Typical effluent biochemical oxygen demand (BOD) and total suspended solids (TSS) were assumed between 10 and 30 milligrams per liter (mg/L) for such a facility and no designed nutrient or toxics removal was assumed for the baseline existing treatment process.

Following a literature review of technologies, four advanced treatment processes for toxics removal were selected for further evaluation based on the characterization of removal effectiveness from the technical literature review and Study Partners’ preferences. The combinations of advanced treatment processes led to four scenarios, all added to the baseline treatment:

- Ultrafiltration (UF)/Reverse Osmosis (RO)
- Ultrafiltration (UF)/Granular Activated Carbon (GAC)
- Ultrafiltration (UF)/ Advanced Oxidation Process (AOP)/ Granular Activated Carbon (GAC)
- Ultrafiltration (UF)/ Advanced Oxidation Process (AOP)/ Granular Activated Carbon (GAC)/Reverse Osmosis (RO)



The advanced treatment technologies are evaluated for their efficacy and cost to achieve the effluent limitations implied by the more stringent HHWQC. Various sensitivities are examined for a size range of treatment systems. Collateral environmental impacts associated with the operation of advanced technologies are also qualitatively described.

## 2 Derivation of the Baseline Study Conditions and Rationale for Selection of Effluent Limitations

Four pollutants were selected for study based on available monitoring data and abundance in the environment. The four toxic constituents are arsenic, benzo(a)pyrene (BAP), mercury, and polychlorinated biphenyls (PCBs).

### 2.1 Background

The Study Partners have selected four pollutants for which more stringent HHWQC are expected to be promulgated. Available monitoring information indicates these pollutants are ubiquitous in the environment and are expected to be present in many NPDES discharges. The four pollutants include the following:

- Arsenic
  - Elemental metalloid that occurs naturally and enters the environment through erosion processes. Also widely used in batteries, pesticides, wood preservatives, and semiconductors. Other current uses and legacy sources in fungicides/herbicides, copper smelting, paints/dyes, and personal care products.
- Benzo(a)pyrene (BAP)
  - Benzo(a)pyrene is a polycyclic aromatic hydrocarbon formed by a benzene ring fused to pyrene as the result of incomplete combustion. Its metabolites are highly carcinogenic. Sources include wood burning, coal tar, automobile exhaust, cigarette smoke, and char-broiled food.
- Mercury
  - Naturally occurring element with wide legacy uses in thermometers, electrical switches, fluorescent lamps, and dental amalgam. Also enters the environment through erosion processes, combustion (especially coal), and legacy industrial/commercial uses. Methylmercury is an organometallic that is a bioaccumulative toxin. In aquatic systems, an anaerobic methylation process converts inorganic mercury to methylmercury.
- Polychlorinated Biphenyls (PCBs)
  - Persistent organic compounds historically used as a dielectric and coolant in electrical equipment and banned from production in the U.S. in 1979. Available information indicates continued pollutant loadings to the environment as a byproduct from the use of some pigments, paints, caulking, motor oil, and coal combustion.

## 2.2 Assumptions Supporting Selected Ambient Water Quality Criteria and Effluent Limitations

The study design necessarily required certain assumptions to create a “baseline effluent scenario” against which the evaluation of advanced treatment technologies could occur. The Study Partners and HDR Engineering, Inc (HDR) developed the scenario. Details of the baseline effluent scenario are presented in Table 2-1. The essential assumptions and rationale for selection are presented below:

- It is assumed that EPA’s April 2022 HHWQC proposal will be promulgated (and effectively replace the HHWQC in the current adopted WAC 173-201A-240 *Toxic Substances*). Table 2-1 summarizes the proposed EPA human health criteria for Washington in comparison with the existing Washington state criteria for the key parameters selected for evaluation; arsenic, benzo(a)pyrene (BAP), mercury, and polychlorinated biphenyls (PCBs).
- The evaluation scenario generally assumes that EPA’s proposed HHWQC for ambient waters will become effluent limitations for many Washington NPDES permittees. The reasoning for this important assumption includes:
  - The state of Washington’s NPDES permitting program is bound by the *Friends of Pinto Creek vs. EPA* decision in the United States Court of Appeals for the Ninth Circuit (October 4, 2007). This decision held that no NPDES permits authorizing new or expanded discharges of a pollutant into a waterbody identified as impaired, i.e. listed on CWA section 303(d) for that pollutant, may be issued until such time as “existing dischargers” into the waterbody are “subject to compliance schedules designed to bring the (waterbody) into compliance with applicable water quality standards.” In essence, any new/expanded discharge of a pollutant causing impairment must achieve the HHWQC at the point of discharge into the waterbody.
  - If a waterbody segment is identified as “impaired” (i.e., not achieving a HHWQC), then Ecology will eventually need to produce a TMDL or water cleanup plan. For an existing NPDES permittee with a discharge of the pollutant for which the receiving water is impaired, the logical assumption is that any waste load allocation granted to the discharger will be at or lower than the numeric HHWQC (to facilitate recovery of the waterbody to HHWQC attainment). As a practical matter, this equates to an effluent limit established at the HHWQC.
  - The assumption is that no mixing zone is granted such that HHWQC will effectively serve as NPDES permit effluent limits. Prior discussion on the impact of the Pinto Creek decision, 303(d) impairment and TMDL Waste Load Allocations processes, all lend support to this “no mixing zone” condition for the parameters evaluated in this study.
  - EPA’s proposed methylmercury tissue concentration criteria of 0.03 mg/kg would translate to water column concentrations lower than the

approved analytical methods in 40 CFR part 136 for Method 1631E with a quantitation level of 0.0005 µg/L. Therefore, dischargers would need to target non-detectable levels of effluent mercury less than 0.0005 µg/L.

- The assumed effluent limit for arsenic is taken from EPA's *National Recommended Water Quality Criteria* (2012) (inorganic, water, and organisms,  $10^{-6}$  excess cancer risk). EPA promulgated arsenic HHWQC for Washington in the National Toxics Rule of 1992. EPA's federal rule in 2016 moved the arsenic criteria from 40 CFR 131.36 to 40 CFR 131.45. In 2019, EPA reversed its disapproval of some HHWQC for Washington, but left its disapproval of criteria for arsenic in place.
- Consistent with Ecology practice in the evaluation of proposed regulations, the HHWQC are assumed to be in effect for a 20-year period. It is assumed that analytical measurement technology and capability will continue to improve over this time frame and this will result in the detection and lower quantification of additional HHWQC in ambient water and NPDES discharges. In parallel fashion, it is assumed that Department of Ecology (and other state and federal agencies) will expand the reach, frequency, and speciation of toxic pollutants (and fish tissue) in ambient waterbodies. This constantly expanding knowledge base seems likely to reveal waterbody impairment and the presence of HHWQC in NPDES permittee discharges at concentrations above the very stringent HHWQC.
- It is assumed that NPDES permits will be renewed on a 5-year schedule and that the Department of Ecology will complete its statutory Clean Water Act Section 303(d) impaired pollutant/waterbody assessment on a 2-year frequency. While history suggests this pace of work may not happen, there should still be 3 to 4 occasions in the 20-year cycle when regulatory determinations on ambient/receiving waters and the resulting NPDES permitting evaluations occur.
- Ecology has a statutory obligation to provide a Significant Legislative Rule evaluation, one element of which is a "determination whether the probable benefits of the rule are greater than its probable costs, taking into account both the qualitative and quantitative benefits and costs and the specific directives of the statute being implemented" (RCW 34.05.328(1)(d)). EPA's April 2022 HHWQC proposal explains that its analysis as follows:

"...did not identify any incremental costs to any major point source discharge of process wastewater from POTW's or industrial facilities attributable to the proposed criteria revisions." (87 FR page 19059, April 1, 2022)

EPA recognizes there may be the following:

"...costs to point sources over time to implement controls or modify processes to meet future permit limits...But it would be highly speculative to attempts to estimate potential costs either based on the possibility of measuring pollutant levels at lower levels as a result of future requirements or future technology..." (87 FR 19059, April 1, 2002)



This HDR Treatment Technology Review and Assessment is intended to provide information to allow comment on the EPA proposal and eventually Washington's Significant Legislative Rule obligation.

Other elements of the Study Partners work scope, as presented to HDR, must be noted:

- The selection of four toxic pollutants and development of a baseline effluent scenario is not meant to imply that each NPDES permittee wastewater discharge will include those pollutants at the assumed concentrations. Rather, the scenario was intended to represent a composite of many NPDES permittees and to facilitate evaluation of advanced treatment technologies relying on mechanical, biological, physical and chemical processes.
- The scalability of advanced treatment technologies to wastewater treatment systems with different flow capacities, and the resulting unit costs for capital and O&M, is evaluated.

Table 2-1. Summary of Effluent Discharge Toxics Limits

Constituent	Human Health Criteria based Limits to be met with no Mixing Zone (µg/L)	Basis for Criteria	Typical Concentration in Municipal Secondary Effluent (µg/L)	Typical Concentration in Industrial Secondary Effluent (µg/L)	Existing Washington HHC WAC 173-201A (water + org.) (µg/L)
Arsenic	0.018	EPA Federal Register 2022 Inorganic Arsenic (water + organisms)	0.500 to 5.0 <sup>a</sup>	10 to 40 <sup>a</sup>	10 <sup>b</sup>
Benzo(a)Pyrene	0.000016	EPA Federal Register 2022 (water + organisms)	0.00028 to 0.006 <sup>c,d</sup>	0.006 to 1.9	0.0014
Mercury	0.0005	EPA Federal Register 2022 Methylmercury (organisms only) EPA Method 1631E <sup>e</sup>	0.003 to 0.050 <sup>f</sup>	0.010 to 0.050 <sup>f</sup>	0.14 <sup>g</sup>
PCBs	0.000007	EPA Federal Register 2022 Total PCBs (water + organisms)	0.0005 to 0.0025 <sup>c,h,i,j,k</sup>	0.002 to 0.005 <sup>l</sup>	0.00017

<sup>a</sup> Best professional judgment (HDR 2013)

<sup>b</sup> Washington Human Health Criteria for Total Arsenic is the maximum contaminant level (MCL) developed under the Safe Drinking Water Act. The MCL for total arsenic is applied to surface waters where consumption of organisms-only and where consumption of water + organisms reflect the designated uses.

<sup>c</sup> Control of Toxic Chemicals in Puget Sound, Summary Technical Report for Phase 3: Loadings from POTW Discharge of Treated Wastewater, Washington Department of Ecology, Publication Number 10-10-057, December 2010.

<sup>d</sup> Removal of Polycyclic Aromatic Hydrocarbons and Heterocyclic Nitrogenous Compounds by A POTW Receiving Industrial Discharges, Melcer, H., Steel, P. and Bedford, W.K., Water Environment Federation, 66th Annual Conference and Exposition, October 1993.

<sup>e</sup> This range of potential water column concentrations for methylmercury associated with EPA's proposed 0.03 mg/kg tissue concentration are lower than the approved analytical methods in 40 CFR part 136 for Method 1631E with a quantitation level of 0.0005 µg/L. Consequently, treatment facilities would need to target non-detectable levels of effluent methylmercury less than 0.0005 µg/L.

<sup>f</sup> Data provided by Lincoln Loehr's summary of WDOE Puget Sound Loading data in emails from July 19, 2013.

<sup>g</sup> Washington Human Health Criteria for Mercury cross-references the EPA National Toxics Rule, 40 CFR 131.36.

<sup>h</sup> Spokane River PCB Source Assessment 2003-2007, Washington Department of Ecology, Publication No. 11-03-013, April 2011.

<sup>i</sup> Lower Okanogan River Basin DDT and PCBs Total Maximum Daily Load, Submittal Report, Washington Department of Ecology, Publication Number 04-10-043, October 2004.

<sup>j</sup> Palouse River Watershed PCB and Dieldrin Monitoring, 2007-2008, Wastewater Treatment Plants and Abandoned Landfills, Washington Department of Ecology, Publication No. 09-03-004, January 2009

<sup>k</sup> A Total Maximum Daily Load Evaluation for Chlorinated Pesticides and PCBs in the Walla Walla River, Washington Department of Ecology, Publication No. 04-03-032, October 2004.

<sup>l</sup> NCASI memo from Larry Lefleur, NCASI, to Llewellyn Matthews, NWPPA, revised June 17, 2011, summarizing available PCB monitoring data results from various sources.



## 2.2.1 Mercury

The water quality criteria for mercury adopted in most states for the protection of aquatic life and human health is generally in the range of 1 to 50 ppt (EPA 2007). Washington's water quality criteria are based on the 1992 National Toxics Rule (40 CFR 131.26) as summarized in (Table ) (Ecology 2016). EPA approved analytical methods include Method 245.7 Mercury in Water for determination of mercury (Hg) in filtered and unfiltered water by cold-vapor atomic fluorescence spectrometry (CVAFS) with a quantitation level of 5.0 ng/L and Method 1631E Ultra Low-Level Mercury in Water by Oxidation, Purge & Trap, and Cold Vapor Atomic Fluorescence Spectrometry 1631E with a quantitation level of 0.5 ng/L.

**Table 2-2. Washington's Water Quality Standards for Mercury**

Washington State Water Quality Standards (WAC 173-201A) Aquatic Life Criteria				National Toxics Rule (NTR) Human Health Criteria (1992)	
Acute Freshwater (µg/L)	Chronic Freshwater (µg/L)	Acute Marine (µg/L)	Chronic Marine (µg/L)	Organism Only (µg/L)	Organism + Water (µg/L)
2.1 <sup>a,b,c,d</sup>	0.012 <sup>d,e,f,g,h</sup>	1.8 <sup>a,b,d,i</sup>	0.025 <sup>e,f,g,h</sup>	0.15 <sup>j,k</sup>	0.14 <sup>j,k</sup>

<sup>a</sup> Dissolved.

<sup>b</sup> A 1-hour average concentration not to be exceeded more than once every three years on average.

<sup>c</sup> The conversion factor used to calculate the dissolved metal concentration was 0.85.

<sup>d</sup> These ambient criteria in the table are for the dissolved fraction. The cyanide criteria are based on the weak acid dissociable method. The metals criteria may not be used to calculate total recoverable effluent limits unless the seasonal partitioning of the dissolved to total metals in the ambient water are known. When this information is absent, these metals criteria shall be applied as total recoverable values, determined by back-calculation, using the conversion factors incorporated in the criterion equations. Metals criteria may be adjusted on a site-specific basis when data are made available to the department clearly demonstrating the effective use of the water effects ratio approach established by USEPA, as generally guided by the procedures in USEPA Water Quality Standards Handbook, December 1983, as supplemented or replaced by USEPA or ecology. The adjusted site-specific criteria are not in effect until they have been incorporated into this chapter and approved by EPA. Information which is used to develop effluent limits based on applying metals partitioning studies or the water effects ratio approach shall be identified in the permit fact sheet developed pursuant to WAC 173-220-060 or 173-226-110, as appropriate, and shall be made available for the public comment period required pursuant to WAC 173-220-050 or 173-226-130(3), as appropriate. Ecology has developed supplemental guidance for conducting water effect ratio studies.

<sup>e</sup> Edible fish tissue concentration shall not be allowed to exceed 1.0 mg/kg of methylmercury.

<sup>f</sup> A 4-day average concentration not to be exceeded more than once every three years on the average.

<sup>g</sup> These criteria are based on the total-recoverable fraction of the metal.

<sup>h</sup> If the four-day average chronic concentration is exceeded more than once in a three-year period, the edible portion of the consumed species should be analyzed. Said edible tissue concentrations shall not be allowed to exceed 1.0 mg/kg of methylmercury.

<sup>i</sup> Marine conversion factors (CF) which were used for calculating dissolved metals concentrations are given below. Conversion factors are applicable to both acute and chronic criteria for all metals except mercury. The CF for mercury was applied to the acute criterion only and is not applicable to the chronic criterion. Conversion factors are already incorporated into the criteria in the table. Dissolved criterion = criterion x CF. Mercury CF = 0.85.

<sup>j</sup> Total.

<sup>k</sup> The human health criteria for mercury are contained in 40 C.F.R. 131.36. EPA 2022

## Methylmercury Criteria

Once in the water, mercury can convert to the form methylmercury, which accumulates in fish and aquatic organisms. Consumption of exposed fish and aquatic organisms can lead to human health issues. Federal water quality criteria for methylmercury have been promulgated for surface waters in Washington (CFR 2022b). The applicable human health criteria are shown in Table .

**Table 2-3. Proposed Methylmercury Human Health Criteria for Washington**

Chemical	CAS No.	Relative source contribution, RSC (-)	Reference dose RfD (mg/kg d)	Organisms Only (µg/L)	Water & Organisms (µg/L)
Methylmercury	22967926	2.7E-05	0.0001	0.03 (mg/kg) <sup>a</sup>	{blank}

<sup>a</sup> This criterion is expressed as the fish tissue concentration of methylmercury (mg methylmercury/kg fish). See Water Quality Criterion for the Protection of Human Health: Methylmercury (EPA-823-R-01-001, January 3, 2001) for how this value is calculated using the criterion equation in the EPA's 2000 Human Health Methodology rearranged to solve for a protective concentration in fish tissue rather than in water.

## Translation of Mercury Criteria

“The methylmercury criterion was the first EPA-developed HHC expressed as a fish and shellfish tissue value rather than as a water column value. EPA recognized that this approach differed from traditional water column criteria and might pose implementation challenges” (Ecology 2016).

Translation of the 0.03 mg/kg tissue concentration (Table 2-3) to a water column concentration is likely to result in values that are very low and lower than the analytical methods available for mercury (Method 1631E quantitation level of 0.0005 µg/L). The Washington water column concentration level of 0.012 µg/L (Table 2-2) was based on an edible fish tissue concentration not exceeding 1.0 mg/kg of methylmercury. A fish tissue concentration of 0.03 mg/kg is nearly two orders of magnitude lower, which implies a water column concentration far lower than 0.012 µg/L.

EPA's methylmercury criteria implementation guidance document outlines various options for translating fish tissue criteria into water column criteria (EPA 2010). As noted in the guidance document, translation is challenging because of numerous site-specific factors that can affect bioaccumulation, as well as the relative proportions of methyl and total mercury in the water column. As an example translation of methylmercury criteria to a water column concentration, a number of assumptions were made to apply EPA's methylmercury criteria implementation guidance document (NACASI 2022). EPA published national bioaccumulation factors (BAF) which are 680,000 L/kg for trophic level 3 fish and 2,700,000 L/kg for trophic level 4 fish. Assuming human consumption of 25 percent trophic level 3 fish and 75 percent trophic level 4 fish, the weighted BAF is approximately 2,200,000 L/kg. For human consumption of 25 percent trophic level 3 fish and 75 percent trophic level 4 fish, a person might consume a combination of some farm raised salmon and trout (trophic 3) along with tuna and wild caught salmon (trophic 4). Dividing the 0.03 mg/kg tissue criteria by the weighted BAF results in an equivalent water column concentration of approximately 0.000014 µg/L. Alternatively, assuming

consumption of 100 percent trophic level 2 fish where a person might consume mostly sardines, tilapia, and catfish, results in a BAF of approximately 120,000 L/kg. That translates to an equivalent water column concentration of approximately to 0.00025 µg/L. This range of potential equivalent water column concentrations of 0.000014 µg/L to 0.00025 µg/L is less than the Method 1631E quantitation level of 0.0005 µg/L. Consequently, treatment facilities would need to target non-detectable levels of methylmercury (NACSI 2022).

Ecology notes that Washington waters have a wide range of dissolved organic carbon (DOC) and particulate organic carbon (POC) concentrations. This means the national BAFs that were calculated using national default POCs and DOCs likely are not reflective of BAFs in many of Washington’s waters (Ecology 2016). “Ecology has decided to defer state adoption of HHC for methylmercury at this time and plans to schedule adoption of methylmercury criteria and develop a comprehensive implementation plan after the current rulemaking is completed and has received Clean Water Act approval” (Ecology 2016).

## 2.3 Analytical Methods

The test procedures identified in CFR Title 40 Part 136 (CFR 2022b) specify the detection limits and quantitation levels for the analytical methods. When the detection limit and quantitation levels is not obtained, a matrix-specific detection limit with appropriate laboratory documentation is required. The approved analytical laboratory procedures for arsenic and mercury are listed in Table 2 4.

**Table 2-4. CFR Part 136 List of Approved Inorganic Test Procedures**

Parameter	Methodology	EPA	Standard Methods	ASTM	USGS/AOAC/Other
Arsenic, Total (mg/L)	Digestion, followed by any of the following	206.5 (Issued 1978)	--	--	--
	AA gaseous hydride	--	3114 B-2011 or 3114 C-2011	D2972-15 (B)	I-3062-85
	AA furnace	--	3113B-2010	D2972-15 (C)	I-4063-98
	STGFAA	200.9 Rev 2.2 (1994)	--	--	--
	ICP/AEC	200.5 Rev 4.2 (2003), 200.7 Rev 4.4 (1994)	3120 B-2011	D1976-12	--
	ICP/MS	200.8 Rev 5.4 (1994)	3125 B-2011	D5673-16	993.14, I-4020-05
	Colorimetric (SDDC)	--	350-As B-2011	D2972-15 (A)	I-3060-85
Mercury, Total (mg/L)	Cold vapor, Manual	245.1 Rev 3.0 (1994)	3112 B-2011	D3223-17	977.22, I-3462-85

Parameter	Methodology	EPA	Standard Methods	ASTM	USGS/AOAC/Other
	Cold vapor, Automated	245.2 (Issued 1974)	--	--	--
	Cold vapor, atomic fluorescence spectrometry (CVAFS)	245.7 Rev 2.0 (2005)	--	--	I-4464-01
	Purge and Trap CVAFS	1631E	--	--	--

The approved analytical laboratory procedures for benzo(a)pyrene (BAP) and polychlorinated biphenyls (PCBs) are listed in Table 2.5.

**Table 2-5. CFR Part 136 List of Approved Test Procedures for Non-Pesticide Organic Compounds**

Parameter	Methodology	EPA	Standard Methods	ASTM	USGS/AOAC/Other
Benzo(a)pyrene	GC	610	--	--	--
	GC/MS	625.1, 1625B	6410 B-2000	--	Note
	HPLC	610	6440 B-2005	D4657-92 (98)	--
PCB	GC	608.3	6410 B-2000	--	Note
	GC/MS	625.1	--	--	--

Table 2-6 summarizes the analytical laboratory detection levels and quantitation levels for arsenic, BAP, mercury, and PCBs. Detection level or detection limit means the minimum concentration of an analyte (substance) that can be measured and reported with a 99 percent confidence that the analyte concentration is greater than zero as determined by the procedure given in 40 CFR part 136, Appendix B.

Quantitation level, also known as minimum level of quantitation, is the lowest level at which the entire analytical system must give a recognizable signal and acceptable calibration point for the analyte. It is equivalent to the concentration of the lowest calibration standard, if the laboratory has used all method-specified sample weights, volumes, and cleanup procedures.

The proposed water quality standards for arsenic, BAP, mercury, and PCBs are very low concentration values, which in some cases are lower than the analytical laboratory methods are capable of detecting or quantifying.

**Table 2-6. Summary of Analytical Laboratory Techniques Standard Levels**

Parameter	Method Protocol	Detection Limit	Quantitation Level
Arsenic, Total	200.8	0.1 µg/L	0.5 µg/L
Mercury, Total	1631E	0.00005 µg/L	0.0005 µg/L
Benzo(a)Pyrene	610/625	0.5 µg/L	1.0 µg/L
PCB	608	0.25 µg/L	0.5 µg/L

The only method currently approved at 40 CFR Part 136 for monitoring PCBs in wastewater is Method 608.3 which targets only seven common Aroclor mixtures. Since most PCB contamination in the environment is highly weathered and often does not resemble any of the Aroclor mixtures, and there are non-Aroclor sources of PCB in the environment, Aroclor results are likely to underestimate total PCB levels or result in non-detect reports in a sample when compared to the analysis of individual PCB congeners. Congener methods identified in Table 2-7 are not yet approved at 40 CFR Part 136 for monitoring PCBs. Method 1628 detects all 209 PCB congeners and quantifies them either directly or indirectly. A total of 29 carbon-13 labeled PCB congeners are used as isotope dilution quantification standards. An additional 19 congeners are quantified by an extracted internal standard procedure, using one of the isotope dilution standards. The remaining 144 congeners are quantified against a labeled standard in the same homolog. This approach strikes a balance between enabling the laboratory to detect and quantify all 209 congeners, while not making the method too arduous. Method 1628 is not yet approved at 40 CFR Part 136 for use in Clean Water Act compliance monitoring (EPA 2022b).

Method 1668 determines chlorinated biphenyl congeners in environmental samples by isotope dilution and internal standard high-resolution gas chromatography/high-resolution mass spectrometry (HRGC/HRMS). EPA developed this method for use in wastewater, surface water, soil, sediment, biosolids and tissue matrices (EPA 2010). In water, detection limits range from approximately 7 to 77 parts per quadrillion (picograms per liter, pg/L) and quantitation levels range from approximately 20 to 200 pg/L, depending on the congener. The chlorinated biphenyls that can be determined by this Method are the 12 polychlorinated biphenyls (PCBs) designated as toxic by the World Health Organization (WHO): congeners 77, 81, 105, 114, 118, 123, 126, 156, 157, 167, 169, and 189. The Method also determines the remaining 197 chlorinated biphenyls, approximately 125 of which are resolved adequately on an SPB-octyl gas chromatographic column to be determined as individual congeners. The remaining approximately 70 congeners are determined as mixtures of isomers (co-elutions).

**Table 2-7. Currently Not Approved Analytical Methods Pending Future Decisions**

Parameter	EPA Method
PCB	1628
	1668

Table 2-8 presents a comparison of the analytical detection limit and quantitation level for arsenic, BAP, mercury, and PCBs with the EPA version of the Washington human health water quality standards,

**Table 2-8. Comparison of Analytical Laboratory Techniques Standard Levels and Water Quality Standards**

Parameter	Method Protocol	Detection Limit	Quantitation Level	EPA Proposed Water Quality Standard (Federal Register 2022)
Arsenic, Total	200.8	0.1 µg/L	0.5 µg/L	Water & Organisms 0.018 µg/L Organisms Only 0.14 µg/L This criterion refers to the inorganic form of arsenic only.
Mercury, Total	1631E	0.00005 µg/L	0.0005 µg/L	Methylmercury Organisms Only 0.03 mg/kg This criterion is expressed as the fish tissue concentration of methylmercury (mg methylmercury/kg fish). See Water Quality Criterion for the Protection of Human Health: Methylmercury (EPA-823-R-01-001, January 3, 2001) for how this value is calculated using the criterion equation in EPA's 2000 Human Health Methodology rearranged to solve for a protective concentration in fish tissue rather than in water.
Benzo(a)Pyrene	610/625	0.5 µg/L	1.0 µg/L	Water & Organisms 1.6E-05 µg/L Organisms Only 1.6E-05 µg/L
PCB	608	0.25 µg/L	0.5 µg/L	Water & Organisms 7E-06 µg/L Organisms Only 7E-06 µg/L This criterion applies to total PCBs (e.g., the sum of all congener or isomer or homolog or Aroclor analyses).

### 3 Wastewater Characterization Description

This section describes the wastewater treatment discharge considered in this technology evaluation. Treated wastewater characteristics are described, including average and peak flow, effluent concentrations, and toxic compounds of concern.

#### 3.1 Summary of Wastewater Characterization

A general wastewater treatment process with industry accepted wastewater characteristics was developed as the common baseline to represent a starting point for comparison with potential future advanced treatment technologies and improvements. The baseline included a secondary treatment process with disinfection sized for annual average flows of 5 mgd. Effluent limits for biochemical oxygen demand (BOD) and total suspended solids (TSS) were assumed to be between 10 to 30 mg/L from such a facility. No nutrient or human health toxics removal was assumed to be accomplished in the existing baseline treatment process.

#### 3.2 Baseline Wastewater Treatment Facility

The first step in the process is to define the baseline wastewater treatment plant to be evaluated in this study. The goal is then to identify the additional technology needed to comply with revised toxic pollutant effluent limits. Rather than evaluating the technologies and costs to upgrade multiple actual operating facilities, the Study Partners specified that a generalized municipal/industrial wastewater treatment facility would be defined and used as the basis for developing toxic removal approaches. Characteristics of the facility's flows and effluent are described in Table 3-1.

**Table 3-1. General Wastewater Treatment Facility Characteristics**

Average Annual Wastewater Flow, mgd	Maximum Month Wastewater Flow, mgd	Peak Hourly Wastewater Flow, mgd	Effluent BOD, mg/L	Effluent TSS, mg/L
5.0	6.25	15.0	10 to 30	10 to 30

mgd = million gallons per day  
 mg/L = milligrams per liter

In the development of the advanced treatment technologies presented below, the capacities of major treatment elements are generally sized to accommodate the maximum month average wastewater loads with ability to accommodate peak hourly flows. Hydraulic elements, such as pumps and pipelines, were selected to accommodate the peak hourly wastewater flow.

The general treatment facility incorporates baseline treatment processes including influent screening, grit removal, primary sedimentation, suspended growth biological treatment (activated sludge), secondary clarification, and disinfection using chlorine. Solids removed during primary treatment and secondary clarification are assumed to be

thickened, stabilized, dewatered, and land applied to agricultural land. The biological treatment process is assumed to be activated sludge with a short SRT (less than 4-days). The baseline secondary treatment facility is assumed not to have processes dedicated to removing nutrients or toxics. However, some coincident removal of toxics will occur during conventional treatment.

### 3.3 Toxic Constituents

As described in Section 2.2, the expectation of more stringent HHWQC will eventually trigger regulatory demands for NPDES permittees to install advanced treatment technologies. The Study Partners selected four specific toxic pollutants reflecting a range of toxic constituents as the basis for this study to limit the constituents and technologies to be evaluated to a manageable level.

The four toxic pollutants selected for review were as follows:

- Polychlorinated Biphenyls (PCBs)
- Mercury
- Arsenic
- BAP, a polycyclic aromatic hydrocarbon (PAH)

Mercury and arsenic are metals, and PCBs and PAHs are organic compounds. Technologies for removing metals and organic compounds are in some cases different. Key information on each of the compounds, including a description of the constituent, the significance of each constituent, proposed HHWQC based effluent limits, basis for the proposed criteria, typical concentration in both municipal and industrial secondary effluent, and current Washington state water quality criteria, are shown in Table 2-1. It is assumed that compliance with the proposed criteria in the table would need to be achieved at the “end of pipe” and Ecology would not permit a mixing zone for toxic constituents. This represents a “worst–case” scenario, but it is a plausible assumption about discharge conditions given that the HHWQ criteria are such low concentrations that ambient receiving waters may be near, or already exceed these levels, and not provide an opportunity for effluent dilution.



## 4 Treatment Approaches and Costs

Four advanced treatment process options for toxics removal were selected for further evaluation based on the characterization of removal effectiveness from the technical literature review and Study Partners preferences. Four tertiary treatment options (RO or GAC based) with and without AOP were considered as follows (all options were added to the baseline secondary treatment):

- RO Based:
  - UF/RO
  - UF/AOP/GAC/RO
- GAC Based:
  - UF/GAC
  - UF/AOP/GAC

Based on the literature review, it is not anticipated that any of the treatment options will be effective in reducing all of the selected pollutants to below the anticipated water quality criteria. A summary of the capital and operations and maintenance costs for tertiary treatment is provided, as well as a comparison of the adverse environmental impacts for each advanced treatment alternative.

### 4.1 Constituent Removal – Literature Review

The evaluation of treatment technologies relevant to the constituents of concern was initiated with a literature review. The literature review included a desktop search using typical web-based search engines, and search engines dedicated to technical and research journal databases. Additionally, HDR's experience with the performance of treatment technologies specifically related to the four constituents of concern was used in evaluating candidate technologies. A summary of the constituents of concern and relevant treatment technologies is provided in the following literature review section.

#### 4.1.1 Arsenic

The anticipated required HHWQC effluent limit for arsenic is 0.018 µg/L. A variety of treatment technologies can be applied to capture arsenic (Table 4-1). Most of the information in the technical literature and from the treatment technology vendors is focused on potable water treatment for compliance with a Safe Drinking Water Act (SDWA) maximum contaminant level (MCL) of 10 µg/L. The most commonly used arsenic removal method for a wastewater application (tertiary treatment) is coagulation/flocculation plus filtration. This method by itself could remove more than 90 to 95 percent of arsenic. Additional post-treatment through adsorption, ion exchange, or reverse osmosis is required for ultra-low arsenic limits in the 0.018 µg/L range under consideration. In each case pilot-testing is recommended to confirm effluent quality performance of each selected technology.

Table 4-1. Summary of Arsenic Removal Technologies<sup>1</sup>

Technology	Advantages	Disadvantages
Coagulation/filtration	<ul style="list-style-type: none"> <li>• Simple, proven technology</li> <li>• Widely accepted</li> <li>• Moderate operator training</li> </ul>	<ul style="list-style-type: none"> <li>• pH sensitive</li> <li>• Potential disposal issues of backwash waste</li> <li>• As<sup>+3</sup> and As<sup>+5</sup> must be fully oxidized</li> </ul>
Lime softening	<ul style="list-style-type: none"> <li>• High level of arsenic treatment</li> <li>• Simple operation change for existing lime softening facilities</li> </ul>	<ul style="list-style-type: none"> <li>• pH sensitive (requires post treatment adjustment)</li> <li>• Requires filtration</li> <li>• Significant sludge operation</li> </ul>
Adsorptive media	<ul style="list-style-type: none"> <li>• High As<sup>+5</sup> selectivity</li> <li>• Effectively treats water with high total dissolved solids (TDS)</li> </ul>	<ul style="list-style-type: none"> <li>• Highly pH sensitive</li> <li>• Hazardous chemical use in media regeneration</li> <li>• High concentration SeO<sub>4</sub><sup>-2</sup>, F<sup>-</sup>, Cl<sup>-</sup>, and SO<sub>4</sub><sup>-2</sup> may limit arsenic removal</li> </ul>
Ion exchange	<ul style="list-style-type: none"> <li>• Low contact times</li> <li>• Removal of multiple anions, including arsenic, chromium, and uranium</li> </ul>	<ul style="list-style-type: none"> <li>• Requires removal of iron, manganese, sulfides, etc. to prevent fouling</li> <li>• Brine waste disposal</li> </ul>
Membrane filtration	<ul style="list-style-type: none"> <li>• High arsenic removal efficiency</li> <li>• Removal of multiple contaminants</li> </ul>	<ul style="list-style-type: none"> <li>• Reject water disposal</li> <li>• Poor production efficiency</li> <li>• Requires pretreatment</li> </ul>

<sup>1</sup>Adapted from WesTech

The removal of arsenic in activated sludge is minimal (less than 30 percent) (Andrianisa et al. 2006; Ge et al., 2020), but biological treatment can control arsenic speciation during aerobic biological processes as As (III) is oxidized to As (V). Recent research suggests potential promise in increasing arsenic removal with aerobic granular sludge via biosorption and/or controlled conditions for potentially increasing such removals (Wang et al., 2018; Peng et al., 2018). Research by Ge et al. (2020) suggests that it is more effective to remove As downstream of biological treatment due to lower levels of dissolved organic matter and phosphate in the activated sludge process. Such removal

can occur downstream of activated sludge via coagulation/flocculation/filtration removal, as well as adsorption removal methods, which are more effective in removal of As(V) vs. As (III). A combination of activated sludge and post-activated sludge precipitation with a metal salt (e.g., alum or ferric chloride addition to MLSS and effluent)) can result in a removal efficiency of greater than 95 percent. This combination could decrease As levels from 200 µg/L to less than 5 µg/L (5,000 ng/L) (Andrianisa et al. 2008). Olujimi et al., (2012) found activated sludge could reduce As levels to a range of 0.64 to 2.2 µg/L. However, this is still at least an order-of-magnitude greater than the 0.018 µg/L proposed standard for arsenic.

Data from the West Basin Municipal Water District MF/RO/AOP suggests effluent performance in the range of 0.1 to 0.2 µg/L Effluent concentrations at West Basin could be lower since the analytical detection limit used at West Basin was 0.15 µg/L, however that is still an order of magnitude higher than the proposed HHWQC in Washington. Data from a confidential demonstration project facility using UF/RO/AOP suggests effluent performance as low as <0.036 µg/L. A range of expected enhanced removal rates might be assumed to be equivalent to that achieved at these UF/RO/AOP facilities in the 0.036 to 0.2 µg/L range.

## Review of Specific Technologies for Arsenic Removal

### *Coagulation plus Settling or Filtration*

Coagulation may remove more than 95 percent of arsenic through the creation of particulate metal hydroxides. Ferric sulfite is typically more efficient and applicable to most wastewater sources compared to alum. The applicability and extent of removal should be pilot-tested, since removal efficiency is highly dependent on the local water constituents and water characteristics (i.e., pH, temperature, solids).

Filtration can be added after settling to increase arsenic removal. Example treatment trains with filtration are shown in Figure 4-1 and , respectively.

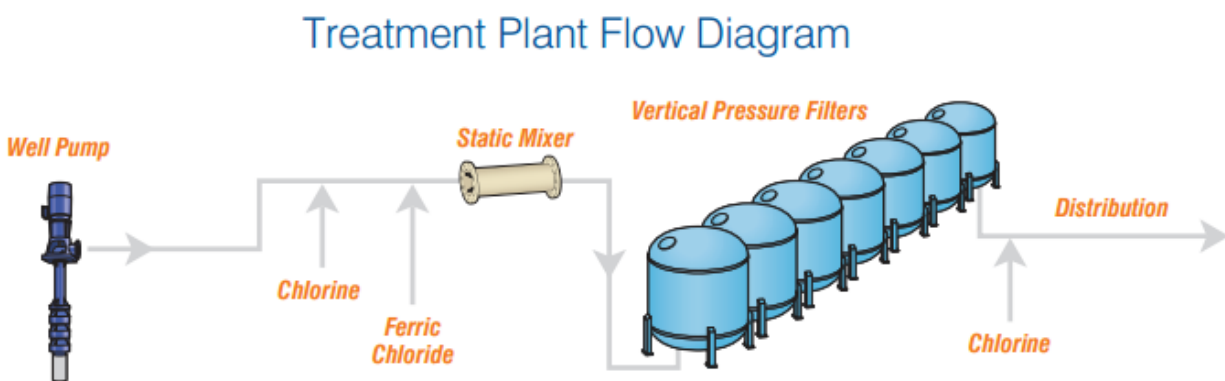

**Figure 4-1. Water Treatment Configuration for Arsenic Removal (WesTech)**

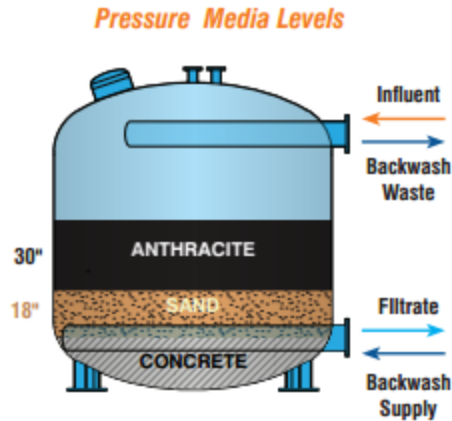

**Figure 4-2. WesTech Pressure Filters for Arsenic Removal**

One system for treatment of potable water with high levels of arsenic in Colorado (110 mg/L) consists of enhanced coagulation followed by granular media pressure filters that include anthracite/silica sand/garnet media (WesTech). The arsenic levels were reduced to less than the drinking water MCL, which is 10 µg/L (10,000 ng/L). The plant achieves treatment by reducing the pH of the raw water to 6.8 using sulfuric acid, and then adding approximately 12 to 14 mg/L ferric sulfate. The water is filtered through 16 deep bed vertical pressure filters, the pH is elevated with hydrated lime and is subsequently chlorinated and fed into the distribution system.

(<https://f.hubspotusercontent10.net/hubfs/541513/content/case-study/Case-Study-Fallon-NV-VPF-SuperSettler.pdf>).

#### *Softening (with lime)*

Removes up to 90 percent arsenic through co-precipitation, but it requires the pH to be higher than 10.2.

#### *Adsorption processes*

Activated alumina is considered an adsorptive media, although the chemical reaction is an exchange of arsenic ions with the surface hydroxides on the alumina. When all of the surface hydroxides on the alumina have been exchanged, the media must be regenerated. Regeneration consists of backwashing, followed by sodium hydroxide, flushing with water and neutralization with a strong acid. Effective arsenic removal requires sufficient empty bed contact time. Removal efficiency can also be impacted by the water pH, with neutral or slightly acidic conditions being considered optimum. If As (III) is present, it is generally advisable to increase empty bed contact time, as As (III) is adsorbed more slowly than As (V). Alumina dissolves slowly over time due to contact with the chemicals used for regeneration. As a result, the media bed is likely to become compacted if it is not backwashed periodically.

Granular ferric hydroxide works by adsorption, but when the media is spent it cannot be regenerated and must be replaced. The life of the media depends upon pH of the raw water, the concentrations of arsenic and heavy metals, and the volume of water treated daily. Periodic backwashing is required to prevent the media bed from becoming compacted and pH may need to be adjusted if it is high, in order to extend media life. For

maximum arsenic removal, filters operate in series. For less stringent removal, filters can operate in parallel.

One type of adsorption media has been developed for application to non-drinking water processes for arsenic, phosphate and for heavy metals removal by sorption (Severn Trent Bayoxide® E IN-20). This granular ferric oxide media has been used for arsenic removal from mining and industrial wastewaters, selenium removal from refinery wastes and for phosphate polishing of municipal wastewaters. Valley Vista drinking water treatment with Bayoxide® E IN-20 media achieves removal from 31-39 µg/L (31,000-39,000 ng/L) to below 10 µg/L MCL

[http://www.severntrentservices.com/News/Successful\\_Drinking\\_Water\\_Treatment\\_in\\_an\\_Arsenic\\_Hot\\_Spot\\_nwMFT\\_452.aspx](http://www.severntrentservices.com/News/Successful_Drinking_Water_Treatment_in_an_Arsenic_Hot_Spot_nwMFT_452.aspx).

Another adsorptive filter media is greensand. Greensand is available in two forms: as glauconite with manganese dioxide bound ionically to the granules and as silica sand with manganese dioxide fused to the granules. Both forms operate in pressure filters and both are effective. Greensand with the silica sand core operates at higher water temperatures and higher differential pressures than does greensand with the glauconite core. Arsenic removal by greensand requires a minimum concentration of iron. If a sufficient concentration of iron is not present in the raw water, ferric chloride is added.

WesTech filters with greensand and permanganate addition for drinking water systems can reduce As from 15 to 25 µg/L to non-detect. Sodium hypochlorite and/or potassium permanganate are added to the raw water prior to the filters. Chemical addition may be done continuously or intermittently, depending on raw water characteristics. These chemicals oxidize the iron in the raw water and also maintain the active properties of the greensand itself. Arsenic removal is via co-precipitation with the iron.

### *Ion Exchange*

Siemens offers a potable ion exchange (PIX) arsenic water filtration system. PIX uses ion exchange resin canisters for the removal of organic and inorganic contaminants, in surface and groundwater sources to meet drinking water standards.

Filtronics also uses ion exchange to treat arsenic. The technology allows removal for below the SWDA MCL for potable water of 10 µg/L (10,000 ng/L).

### *Nanofiltration and Reverse Osmosis*

Arsenic is effectively removed by RO when it is in an oxidative state As(V) to approximately 1 µg/L or less (Ning 2002). While effective, RO has its own inherent challenges when dealing with brine reject as discussed in this paper. A potentially attractive solution is the use of nanofiltration membranes (Worou et al., 2021). While still emerging, such nanofiltration membranes have shown promise as they have exhibited long-term efficiency, fouling reduction, cost reduction, and an increase in separation of multivalent ions, rejection performance, and high flux achievement compared to RO. This *Treatment Technology Review and Assessment* for the Study Partners did not consider nanofiltration membranes as this is still an emerging technology for such applications.

## Summary of Arsenic Technologies

The current state of the technology for arsenic removal is focused on satisfying the 10 µg/L SWDA MCL for arsenic in potable water. The current EPA maximum concentration level for arsenic in drinking water at 10 µg/L is much higher than 0.018 µg/L target for arsenic in this study for Washington. The majority of the treatment technologies discussed above are able to remove arsenic to either the SDWA maximum contaminant level, or to the analytical laboratory level of detection. The lowest detection limit of one of the EPA approved methods of arsenic measurements is 0.020 µg/L (Grosser, 2010), which is comparable to the 0.018 µg/L limit targeted in this study.

Combined processes for arsenic removal, such as MF or UF combined with RO and an AOP process, appear capable of arsenic removal to the same order of magnitude as the Washington HHWQC. Pilot tests would be required at individual treatment plants to determine the lowest concentration achievable on a sustainable and reliable basis. The feasibility of compliance would depend upon the formulation of effluent limits in discharge permits. Compliance with long term average mass loading limits might be feasible, however compliance with maximum day concentration limits would be unlikely.

### 4.1.2 Polycyclic Aromatic Hydrocarbons - Benzo(a)pyrene

The anticipated required HHWQC effluent limit for BAP is 0.000016 µg/L.

#### Benzo(a)pyrene During Biological Treatment

The partitioning behavior for BAPs is well understood with the lower molecular weight compounds primarily in the dissolved form, whereas the higher molecular weight compounds tend to be bound to organic-rich surfaces and/or solids (Schwartzbach et al., 2003). This partitioning behavior applies to wastewater treatment, whereby BAPs which have a high molecular weight have been found to primarily bind to sludge (Melcer et al. 1993; Liu et al, 2017)). Primary and secondary processing could remove up to 69 percent of incoming PAHs and BAP in particular, mostly due to adsorption to sludge (Liu et al., 2017). Such removal levels are comparable with previous research by Kindaichi et al., NA; Wayne et al., 2009) that found removals by primary and secondary processes of up to 60 percent.

Biodegradation of BAP is expected to be very low since there are more than five benzene rings which are resistant to biological degradation. Biosurfactant addition to biological process could partially improve biodegradation, but only marginally (Sponza et al. 2010). Existing data from municipal treatment facilities in Washington state have influent and effluent concentrations of BAP of approximately <0.3 µg/L which suggests that current secondary treatment has limited effectiveness at BAP removal.

Activated Sludge has shown removals to below 0.0057 µg/L, however, this is still two orders-of-magnitude greater than the HHWQC of 0.000016 µg/L (Ecology 2010).

#### Methods to Enhance Biological Treatment of Benzo(a)pyrene

Ozonation prior to biological treatment could potentially improve biodegradability of BAP (Zeng et al. 2000; Yerushalmi et al., 2006). In the case of soil remediation, ozonation

before biotreatment improved biodegradation by 70 percent (Russo et al. 2012). The overall removal of BAP increased from 23 to 91 percent after exposure of water to 0.5 mg/L ozone for 30 minutes during the simultaneous treatment process and further to 100 percent following exposure to 2.5 mg/L ozone for 60 minutes during the sequential treatment mode (Yerushalmi et al. 2006). In general, to improve biodegradability of BAP, long exposure to ozone might be required (Haapea et al. 2006).

A literature review of treating BAP in various water environments support the combination of combined treatment methods, such as ozone followed by biological treatment, is essential for effective BAP removal (Mojiri et al., 2019). Other physical/chemical treatments of interest are sonication pre-treatment, electronic beam irradiation, or activated carbon (Gupta and Gupta, 2016). Such treatments (except activated carbon) break up PAHs into more bioavailable forms for subsequent biological degradation.

Recent studies suggest that a membrane bioreactor (MBR) is capable of removing PAHs from wastewater (Rodrigue and Reilly 2009; González et al. 2012). The removal mechanism in González et al. (2012) suggests a blend of sorption and air stripping with little or no biodegradation. As a result, an MBR would be unlikely to achieve any significant PAH removal at a full-scale facility.

## Removal of Benzo(a)pyrene from Drinking Water

### *Activated Carbon and Biochar*

Since BAP has an affinity to particulate matter, it has been found to be removed from drinking water sources by means of adsorption (e.g., granular activated carbon (GAC) (EPA)). Similarly, Oleszczuk et al. (2012) showed that addition of 5 percent activated carbon could remove 90 percent of PAHs from the wastewater. More recent research has focused on the use of biochar (Oleszczuk et al. (2014). The biochar results were more broadly \ ranging than with GAC (17 to 58 percent reduction of PAHs at 5 percent biochar) and highly dependent on feedstock, biochar particle size, and temperature. In contrast, biochar is promising to further evaluate as it lends itself to a circular economy of recycling.

### *Reverse Osmosis and Nanofiltration*

Light (1981) studied dilute solutions of PAHs, aromatic amines, and nitrosamines and found rejections of these compounds in reverse osmosis to be over 99 percent for polyamide membranes. Bhattacharyya et al. (1987) investigated rejection and flux characteristics of FT30 membranes for separating various pollutants (PAHs, chlorophenols, nitrophenols) and found membrane rejections were high (>98 percent) for the organics under ionized conditions.

While treating landfill leachate, Smol and Włodarczyk-Makula (2017) found that coagulation coupled with nanofiltration and RO resulted in 88 percent removal of PAHs. The coagulation and nanofiltration step removed up to 78 percent of the PAHs, which suggests the nanofiltration step removed the majority of the PAHs.

## Summary of Benzo(a)pyrene Technologies

Current technologies show that BAP removal rates may be approximately 99 percent or greater with a single technology. The lowest detection reported for BAP is 0.0057 µg/L, which is also the secondary effluent BAP concentration assumed for this study (Ecology 2010). Even if it is assumed that an additional 99 percent removal can be achieved with post-secondary treatment, it is unlikely to comply with the HHWQC (99 percent removal of 0.0057 µg/L=0.00057 µg/L which still exceeds the HHWQC). Therefore, it appears that single advanced treatment technologies alone will not remove BAP to the proposed HHWQC levels. Multiple advanced technologies in series may have the ability to further reduce BAP concentrations, however no known processes exist which demonstrate this in testing or full-scale facilities.

### 4.1.3 Mercury

The range of potential water column concentrations for methylmercury associated with EPA's proposed 0.03 mg/kg tissue concentration are lower than the approved analytical methods in 40 CFR part 136 for Method 1631E with a quantitation level of 0.0005 µg/L. Consequently, treatment facilities would need to target non-detectable levels of effluent methylmercury less than 0.0005 µg/L. Therefore, a limit of 0.0005 µg/L is used for comparison to existing treatment plants and to values cited in literature.

It is well-documented that mercury removal from wastewater can be achieved using precipitation, adsorption, filtration, or a combination of these technologies (e.g., Hua et al., 2020). There is no available data to support that achieving ultra-low effluent mercury concentrations near 0.0005 µg/L is possible at full-scale. This review provides a summary of treatment technology options and anticipated effluent mercury concentrations.

Precipitation (and co-precipitation) involves chemical addition to form a particulate and solids separation, using sedimentation or filtration. Precipitation includes the addition of a chemical precipitant and pH adjustment to optimize the precipitation reaction. Chemicals can include metal salts (ferric chloride, ferric sulfate, ferric hydroxide, or alum), pH adjustment, lime softening, or sulfide. A common precipitant for mercury removal is sulfide, with an optimal pH between 7 and 9. The dissolved mercury is precipitated with the sulfide to form an insoluble mercury sulfide that can be removed through clarification or filtration. One disadvantage of precipitation is the generation of a mercury-laden sludge that will require dewatering and disposal. The mercury sludge may be considered a hazardous waste and require additional treatment and disposal at a hazardous waste site. The presence of other compounds, such as other metals, may reduce the effectiveness of mercury precipitation/co-precipitation. For low-level mercury treatment requirements, several treatment steps will likely be required in pursuit of very low effluent targets.

EPA compiled a summary of facilities that are using precipitation/co-precipitation for mercury treatment (EPA, 2007). Three of the full-scale facilities were pumping and treating groundwater and the remaining eight facilities were full-scale wastewater treatment plants. One of the pump and treat systems used precipitation, carbon



adsorption, and pH adjustment to treat groundwater to mercury effluent concentrations of 0.3 µg/L or less.

Adsorption treatment can be used to remove inorganic mercury from water. While adsorption can be used as a primary treatment step, it is frequently used for polishing after a preliminary treatment step (EPA, 2007). One disadvantage of adsorption treatment is that when the adsorbent is saturated, it either needs to be regenerated or disposed of and replaced with new adsorbent. A common adsorbent is GAC. There are several patented and proprietary adsorbents on the market for mercury removal. Adsorption effectiveness can be affected by water quality characteristics, including high solids and bacterial growth, which can cause media blinding. A constant low flow rate to the adsorption beds increases effectiveness (EPA, 2007). The optimal pH for mercury adsorption on GAC is pH 4 to 5; therefore, pH adjustment may be required.

EPA compiled a summary of facilities that are using adsorption for mercury treatment (EPA, 2007). Some of the facilities use precipitation and adsorption as described above. The six facilities summarized included two groundwater treatment and four wastewater treatment facilities. The reported effluent mercury concentrations were all less than 2 µg/L (EPA 2007).

Membrane filtration can be used in combination with a preceding treatment step. The upstream treatment is required to precipitate soluble mercury to a particulate form that can be removed through filtration. According to the EPA summary report, ultrafiltration is used to remove high-molecular weight contaminants and solids (EPA, 2007). The treatment effectiveness can depend on the source water quality since many constituents can cause membrane fouling, decreasing the effectiveness of the filters. One case study summarized in the EPA report showed that treatment of waste from a hazardous waste combustor treated with precipitation, sedimentation, and filtration achieved effluent mercury concentrations less than the detection limit of 0.2 µg/L.

Bench-scale research performed at the Oak Ridge Y-12 Plant in Tennessee evaluated the effectiveness of various adsorbents for removing mercury to below the NPDES limit of 0.012 µg/L and the potential revised limit of 0.051 µg/L (Hollerman et al., 1999). Several proprietary adsorbents were tested, including carbon, polyacrylate, polystyrene, and polymer adsorption materials. The adsorbents with thiol-based active sites were the most effective. Some of the adsorbents were able to achieve effluent concentrations less than 0.051 µg/L but none of the adsorbents achieved effluent concentrations less than 0.012 µg/L. Subsequent research on ultrafiltration pore size membranes using polyvinylamine coating membrane suggests removals as high as 99 percent (Huang et al., 2015). However, coating the membrane with polyvinylamine reduced the water flux significantly so a balance is required between removal rates and full-scale applicability.

Other mercury removal bench-scale and pilot-scale tests have been performed on refinery wastewater to determine treatment technology effectiveness for meeting very low mercury levels (Urgun-Demirtas et al., 2012; 2013). The Urgun-Demirtas paper found, at bench-scale, that MF membranes could achieve mercury concentrations of 0.00055 µg/L and reported UF membranes could achieve levels as low as 0.00014 µg/L using EPA Method 1631E. However, while EPA Method 1631E has a method detection limit (MDL) of 0.00005 µg/L, versus its ML of 0.0005 µg/L, detection limit means the

minimum concentration of an analyte (substance) that can be measured and reported with a 99 percent confidence that the analyte concentration is greater than zero as determined by the procedure given in 40 CFR part 136, Appendix B. The quantitation level, also known as minimum level of quantitation (ML), is the lowest level at which the entire analytical system must give a recognizable signal and acceptable calibration point for the analyte. It is equivalent to the concentration of the lowest calibration standard, if the laboratory has used all method-specified sample weights, volumes, and cleanup procedures. Therefore, while the report lists a level below the ML for UF membranes, the ML is the minimum value that is considered a reliable measurement, and the value of 0.00014 µg/L should be understood to indicate that there was 99 percent confidence that there was a greater than zero mercury level, but not taken as a reliable measurement.

The Great Lakes Initiative water quality criterion for mercury is less than 0.0013 µg/L for municipal and industrial wastewater plants in the Great Lakes region. This research included an initial bench scale test including microfiltration, ultrafiltration, nanofiltration, and reverse osmosis to meet the mercury water quality criterion. The nanofiltration and reverse osmosis required increased pressures for filtration and resulted in increased mercury concentrations in the permeate. Based on this information and the cost difference between the filtration technologies, a pilot-scale test was performed. The 0.04 µm PVDF GE ZeeWeed 500 series membranes were tested. The 0.0013 µg/L water quality criterion for the Great Lakes Region was met under all pilot study operating conditions. The mercury in the refinery effluent was predominantly in particulate form which was well-suited for removal using membrane filtration.

Other emerging technologies for mercury removal/management are being developed, such as the use of carbon nanotubes (CNTs) (e.g., Verma et al., 2019) and the use of wetlands with biochar (Chang et al., 2022). CNTs are gaining traction as they allow user specific surface chemistries to target specific compounds, such as mercury. As for wetlands and biochar, such configurations offer a means to balance natural treatment with mercury management. While both are attractive, they are still emerging for mercury management and thus not considered further as candidate treatment trains in this study.

Based on available data, it appears that existing municipal treatment facilities can reduce effluent mercury to near EPA Method 1631E's minimum level of quantification (ML) of 0.0005 µg/L, but not meet it on non-detect levels. As stated previously, levels below the ML would be needed to satisfy the fish tissue criteria of 0.03 mg/kg. Average effluent mercury is in the range of 0.0012 to 0.0066 µg/L for existing facilities with secondary treatment and enhanced treatment with cloth filters and membranes. The Spokane County plant data range is an average of 0.0012 µg/L to a maximum day of 0.003 µg/L. Addition of advanced treatment processes such as GAC or RO would be expected to enhance removal rates. Data from the West Basin treatment facility in California suggests that at a detection limit of 0.00799 µg/L, mercury is not detected in the effluent from this advanced process train. It is important to note that industrial plants may have higher existing mercury levels and thus the effluent quality that is achievable at an industrial facility may be of lower quality depending upon site specific circumstances.

## Summary of Mercury Technologies

The literature review revealed one paper on mercury removal technologies near or below the revised effluent target/quantitation limit of 0.0005 µg/L. The value of 0.00055 µg/L was achieved by MF membranes, and a value of 0.00014 µg/L was reported using UF membranes. However, as stated previously, this should be seen as an indication that there was a non-zero amount of mercury remaining in the effluent and not an accurate measurement of the actual remaining mercury concentration. Further, these were both from bench-scale testing and not full scale treatment facilities.

### 4.1.4 Polychlorinated Biphenyls

The EPA proposed HHWQC for PCBs is 0.000007 µg/L. PCBs are persistent organic pollutants that can be difficult to remove in treatment. PCB treatment in wastewater can be achieved using oxidation with peroxide, UV + peroxide, filtration, biological treatment, or a combination of these technologies. There is limited information available about achieving ultra-low effluent PCB concentrations near the 0.000007 µg/L range under consideration in the proposed rulemaking process. Dischargers along the Spokane River have been actively developing a technical support document for PCB variances for river discharges (Ecology, Draft 2020). The draft Ecology report suggests removals for various dischargers along the Spokane River remove 65 to 99 percent of PCBs, dependent on treatment technologies in place and other variables (e.g., feed loads). This review provides a summary of treatment technology options and anticipated effluent PCB concentrations.

Research on the effectiveness of ultraviolet (UV) light and peroxide on removing PCBs was tested in bench scale batch reactions (Yu, Macawile, Abella, & Gallardo 2011). The combination of UV and peroxide treatment achieved PCB removal greater than 89 percent, and in several cases exceeding 98 percent removal. The influent PCB concentration for the batch tests ranged from 50 to 100 micrograms per liter (µg/L). The final PCB concentration (for the one congener tested) was <10 µg/L (10,000 ng/L) for all tests and <5 µg/L (5,000 ng/L) for some tests. The lowest PCB concentrations in the effluent occurred at higher UV and peroxide doses.

Pilot testing was performed to determine the effectiveness of conventional activated sludge and a membrane bioreactor to remove PCBs (Bolzonella et al. 2010). EPA Method 1668 was used for the PCB analysis (detection limit of 0.000010 µg/L per congener). Influent to the pilot system was a combination of municipal and industrial effluent. The detailed analysis was for several individual congeners. Limited testing using the Aroclor method (total PCBs) was used to compare the individual congeners and the total concentration of PCBs. Both conventional activated sludge and UF membrane bioreactor (MBR) systems removed PCBs. The effluent UF MBR concentrations ranged from <0.00001 µg/L to 0.00004 µg/L compared to <0.00001 µg/L to 0.00088 µg/L for conventional activated sludge. The pilot testing showed that increased SRT and higher mixed liquor suspended solids concentrations in the MBR system led to increased removal in the liquid stream. More recent studies by Rodenburg et al. (2022) found that membrane filtration resulted in PCB load reductions by approximately 55 percent at

municipal wastewater treatment plants in the Spokane River. However, the UF MBR effluent was still two orders-of-magnitude greater than the proposed HHWQC.

Bench scale studies were completed to test the effectiveness of GAC and biological activated carbon (BAC) for removing PCBs (Ghosh, Weber, Jensen, & Smith 1999). The effluent from the GAC system was 0.800 µg/L. The biological film in the BAC system was presumed to support higher PCB removal with effluent concentrations of 0.200 µg/L. High suspended sediment in the GAC influent can affect performance. It is recommended that filtration be installed upstream of a GAC system to reduce solids and improve effectiveness.

The City of Coeur d'Alene, Idaho operates an Advanced Wastewater Treatment Facility (AWTF) with Tertiary Membrane Filtration (TMF) that discharges to the Spokane River. The TMF facility was designed for achieving low levels of effluent phosphorus, ammonia, and BOD using 0.04 µm nominal pore size PVDF GE ZeeWeed 500 series ultrafiltration (UF) membranes with coagulant addition (alum, polymer). The City's NPDES discharge permit includes Section II.I that requires Best Management Practices for polychlorinated biphenyl (PCB) congeners, in addition to permit required influent, effluent, and receiving water monitoring using EPA Method 1668 (EPA 2013). Laboratory analysis must target MDLs no greater than the MDLs listed in Table 2 of EPA Method 1668 Revision C (EPA-820-R-10-005), for each of the 209 individual PCB congeners. Each congener has an MDL ranging from 7 to 77 pg/L with a median of 14.5 pg/L (or 0.0000145 µg/l). The method reporting limits for PCB congeners in water is 10 to 1,000 picogram/liter (pg/L) (or 0.00001 to 0.0001 µg/l).

The City has collected 7 years of effluent PCB monitoring data with 32 individual sampling events. The PCB totals, both blank corrected and unaltered, were evaluated (Coeur d'Alene 2021). Sample results were "corrected" to account for laboratory contamination. If a sample result is within a certain factor of the laboratory blank, it is removed from the total sum of PCB congener concentrations based on the presumption that the analytical results may not be valid. A "10X" blank correction identifies congeners that are less than ten times the associated blank result and counts these congeners as zero when totaling. Equipment blanks were also run for the effluent sampler and corrected at the 10X level. The range of congener concentrations in the blanks was 0.2 pg/L to 1,170 pg/L with a median of 1.88 pg/L.

Using the City's sampling results dataset, the median concentration of samples gathered from January-February 2015 through September-October 2021 was calculated. The median was selected as a statistical representation of the central tendency to dampen the effect of outlying samples. Whereas the average or mean may be skewed by higher concentrations and the mode may not be appropriate for a small dataset. The sum of the median effluent PCB congener concentrations for uncorrected laboratory results and blank corrected results were 278 pg/L and 117 pg/L respectively (or 0.000278 and 0.000117 µg/l).

Based on limited available data, it appears that existing municipal secondary treatment facilities in Washington state can reduce effluent PCBs to the range of approximately 0.00010 to 0.0015 µg/L. It appears that the best performing existing municipal treatment facility in Washington state with an ultrafiltration membrane can reduce effluent PCBs to

the range of approximately 0.00019 to 0.00063 µg/L. This is based on a limited data set and laboratory blanks covered a range that overlapped with the effluent results (blanks 0.000058 to 0.00061 µg/L).

Addition of advanced treatment processes would be expected to enhance PCB removal rates, but the technical literature does not appear to provide definitive information for guidance for achieving effluent concentrations as low as proposed HHWQC. A range of expected enhanced removal rates may be assumed to vary widely from the level of the reference ultrafiltration MBR of <0.00001 to 0.0004 µg/L.

### Summary of PCB Technologies

The literature review revealed that there are viable technologies available to reduce PCBs to very low concentration levels <0.00001 µg/L, but no research was identified with treatment technologies capable of meeting the HHWQC for PCBs of 0.000007 µg/L. Based on this review, a tertiary process was selected to biologically reduce PCBs and separate the solids using tertiary filtration. Alternately, GAC was investigated as an option to reduce PCBs, although it is not proven that it will meet the effluent limits.

## 4.2 Unit Processes Evaluated

Based on the results of the literature review, a wide range of technologies were evaluated for toxic constituent removal. A listing of the technologies is as follows:

- Chemically enhanced primary treatment (CEPT). This physical and chemical technology is based on the addition of a metal salt to precipitate particles prior to primary treatment, followed by sedimentation of particles in the primaries. This technology has been shown to effectively remove arsenic but there is little data supporting the claims. As a result, the chemical facilities are listed as optional.
- Activated sludge treatment (with a short SRT of approximately 4 days or less). This biological technology is commonly referred to as secondary treatment. It relies on converting dissolved organics into solids using biomass. Having a short SRT is effective at removing degradable organics referred to as BOD compounds for meeting existing discharge limits. Dissolved constituents with a high affinity to adsorb to biomass (e.g., metals, high molecular weight organics, and others) will be better removed compared to smaller molecular weight organics and recalcitrant compounds which will have minimal removal at a short SRT.
- Enhanced activated sludge treatment (with a long SRT of >8 days). This builds on secondary treatment by providing a longer SRT, which enhances sorption and biodegradation. The improved performance is based on having more biomass coupled with a more diverse biomass community, especially nitrifiers, which have been shown to assist in removal of some of the more recalcitrant constituents not removed with a shorter SRT (e.g., lower molecular weight PAHs). There is little or no data available on the effectiveness of this treatment for removing BAP.
- Additional benefits associated with having a longer SRT are as follows:
  - Lower BOD and TSS discharge loads to receiving water

- Improved water quality and benefit to downstream users
  - Lower effluent nutrient concentrations which reduce algal growth potential in receiving waters
  - Reduced receiving water dissolved oxygen demand due to ammonia removal
  - Reduced ammonia discharge, which is toxic to aquatic species
  - Improved water quality for habitat, especially as it relates to biodiversity and eutrophication
  - Secondary clarifier effluent more conditioned for filtration and disinfection
  - Greater process stability from the anaerobic/anoxic zones serving as biological selectors
- Coagulation/Flocculation and Filtration. This two-stage chemical and physical process relies on the addition of a metal salt to precipitate particles in the first stage, followed by the physical removal of particles in filtration. This technology lends itself to constituents prone to precipitation (e.g., arsenic).
  - Lime Softening. This chemical process relies on increasing the pH to either volatilize dissolved constituents or inactivate pathogens. Given that none of the constituents being studied are expected to volatilize, this technology was not carried forward.
  - Adsorptive Media. This physical and chemical process adsorbs constituents to a combination of media and/or biomass/chemicals on the media. There are several types of media, with the most proven and common being GAC. GAC can also serve as a coarse roughing filter.
  - Ion Exchange. This chemical technology exchanges targeted constituents with a resin. This technology is common with water softeners where the hard divalent cations are exchanged for monovalent cations to soften the water. Recently, resins that target arsenic and mercury removal, including activated alumina and granular ferric hydroxides, have been developed. The resin needs to be cleaned and regenerated, which produces a waste slurry that requires subsequent treatment and disposal. As a result, ion exchange was not considered for further.
  - Membrane Filtration. This physical treatment relies on the removal of particles larger than the membranes pore size. There are several different membrane pore sizes as categorized below.
    - Microfiltration (MF): nominal pore size range typically between 0.1 to 1 micron. This pore size targets particles, both inert and biological, and bacteria. If placed in series with coagulation/flocculation upstream, dissolved constituents precipitated out of solution and bacteria can be removed by the MF membrane.
    - Ultrafiltration (UF): nominal pore size range of typically between 0.010 to 0.1 micron. This pore size targets those solids removed with MF

(particles and bacteria) plus viruses and some colloidal material. If placed in series with coagulation/flocculation upstream, dissolved constituents precipitated out of solution can be removed by the UF membrane.

- Nanofiltration (NF): nominal pore size range of typically between 0.001 to 0.010 micron. This pore size targets those removed with UF (particles, bacteria, viruses) plus colloidal material. If placed in series with coagulation/flocculation upstream, dissolved constituents precipitated out of solution can be removed by the NF membrane.
- Membrane Bioreactor (MBR) (with a long SRT). This technology builds on secondary treatment whereby the membrane (microfiltration) replaces the secondary clarifier for solids separation. As a result, the footprint is smaller, the mixed liquor suspended solids concentration can be increased to about 5,000 – 10,000 mg/L, and the physical space required for the facility reduced when compared to conventional activated sludge. As with the activated sludge option operated at a longer SRT, the sorption and biodegradation of organic compounds are enhanced in the MBR process. The improved performance is based on having more biomass coupled with a more diverse biomass community, especially nitrifiers which have been shown to assist in removal of persistent dissolved compounds (e.g., some PAHs). There is little or no data available on effectiveness at removing BAP. Although a proven technology, MBRs were not carried further in this technology review since they are less likely to be selected as a retrofit for an existing activated sludge (with a short SRT) secondary treatment facility. The MBR was considered to represent a treatment process approach more likely to be selected for a new, greenfield treatment facility. Retrofits to existing secondary treatment facilities can accomplish similar process enhancement by extending the SRT in the activated sludge process followed by the addition of tertiary membrane filtration units.
- Reverse Osmosis (RO). This physical treatment method relies on the use of sufficient pressure to osmotically displace water across the membrane surface while simultaneously rejecting most salts. RO is very effective at removing material smaller than the size ranges for the membrane filtration list above, as well as salts and other organic compounds. As a result, it should be more effective than filtration and MBR methods described above at removing dissolved constituents. Although effective, RO produces a brine reject water that must be managed and disposed of separately.
- Advanced Oxidation Processes (AOPs). This broad term considers all chemical and physical technologies that create strong hydroxyl-radicals. Examples of AOPs include Fenton's oxidation, ozonation, ultraviolet/hydrogen peroxide (UV-H<sub>2</sub>O<sub>2</sub>), and others. The radicals produced are rapid and highly reactive at breaking down recalcitrant compounds. AOPs were carried forward because they are expected to break down PCBs and BAP and potentially contribute to enhancing removals when combined with other technologies.

Based on the technical literature review discussed above, a summary of estimated contaminant removal rates by unit treatment process is presented in Table 4-2.

Table 4-2. Contaminants Removal Breakdown by Individual Unit Process

Unit Process	Arsenic	BAP	Mercury	PCBs
Activated Sludge - Short SRT	28-90% removal; final effluents concentrations ranging from 0.64 – 2.2 µg/L <sup>h</sup>	Partial removal by partitioning <0.0057 µg/L <sup>m</sup>	>92% removal by adsorption of mercury onto activated sludge flocs and subsequent settling <sup>g</sup>	80% removal; effluent <0.00088 µg/L  93% removal; average effluent as low as .000660 µg/L <sup>c</sup>
Activated Sludge - Long SRT	28-90% removal; final effluents concentrations ranging from 0.64 – 2.2 µg/L <sup>h</sup>  Potential bio-oxidation of arsenite to arsenate <sup>i</sup>	Partial removal by partitioning and/or partial biodegradation; MBR could potentially remove most of BAP  <0.0057 µg/L <sup>m</sup>	>92% removal by adsorption of mercury onto activated sludge flocs and subsequent settling <sup>g</sup>	>93% removal with a membrane bioreactor, <0.00001 to 0.00004 µg/L (includes membrane filtration) <sup>k</sup>
Ultrafiltration (UF)*	More than 90% removal (rejection of bound arsenic)	90% removal; effluent of 0.1 µg/L (includes sand prefiltration before ultrafiltration) <sup>d</sup>	Effluent of 0.00055 µg/L with microfiltration. <sup>f</sup>  Effluent of 0.00014 µg/L with ultrafiltration. <sup>f</sup>	>93% removal with a UF membrane bioreactor, <0.00001 to 0.00004 µg/L <sup>k</sup>  98% removal; average effluent as low as .0002 µg/L <sup>c,d</sup>  Median 0.000278 µg/L uncorrected and 0.000117 µg/L blank corrected <sup>u</sup>
Reverse Osmosis (RO)	More than 90% removal (rejection of bound arsenic and removal of soluble arsenic) <sup>o</sup>	More than 98% removal <sup>p,q</sup>	80% removal; effluent of 0.0011 µg/L <sup>f</sup>	Expected to have greater removal than Microfiltration or Ultrafiltration
AOP	No removal; potential chemical oxidation of arsenite to arsenate <sup>i</sup>	More than 99% removal <sup>a</sup>	No removal	As much as 98% removal (<0.99 µg/L) <sup>b</sup>
Granular Activated Carbon (GAC)	No removal, removal only when carbon is impregnated with iron	90% removal	<0.300 µg/L (precipitation and carbon adsorption) <sup>s</sup>  <0.051 µg/L (GAC) <sup>t</sup>	<0.800 µg/L. Likely requires upstream filtration <sup>r</sup>
Disinfection	--	--	--	--



Unit Process	Arsenic	BAP	Mercury	PCBs
Combined Processes	UF/RO/AOP: Effluent of <0.036 µg/L Confidential demonstration project <sup>n</sup>			
Lowest Cited Concentration Removal Method	UF/RO/AOP: Effluent of <0.036 µg/L Confidential demonstration project <sup>n</sup>	Activated Sludge: <0.0057 µg/L	Microfiltration: 0.00055 µg/L <sup>f</sup>	UF Membrane Bioreactor: Best: <0.00001 µg/L Average: < 0.0002 µg/L
Required HHWQC based Effluent Quality	0.018 µg/L	0.000016 µg/L	0.0005 µg/L	0.000007 µg/L <sup>d</sup>

\* Values given are for Microfiltration. Actual performance may be better with UF.

a. Ledakowicz et al., 1999. Note this is for lab conditions, not WWTP performance

b. Yu et al., 2011. Note this is for lab conditions, not WWTP performance

c. Rodenburg et al., 2022. Interference/contamination issues were cited for measuring PCBs at this ultra-low level EPA method 1668.

d. Rodenburg et al., 2022. Note that membrane pore size is not given.

e. Smol and Włodarczyk-Makula 2012

f. Urgun-Demirtas et al., 2012. Note that EPA Method 1631E was used for detection. This has a minimum level of quantitation (ML) of 0.0005 µg/L. EPA Method 1631E has a method detection limit (MDL) of 0.00005 µg/L. Detection level or *detection limit* means the minimum concentration of an analyte (substance) that can be measured and reported with a 99 percent confidence that the analyte concentration is *greater than zero* as determined by the procedure given in 40 CFR part 136, Appendix B. The *quantitation level*, also known as minimum level of quantitation (ML), is the lowest level at which the entire analytical system must give a recognizable signal and acceptable calibration point for the analyte. It is equivalent to the concentration of the lowest calibration standard, if the laboratory has used all method-specified sample weights, volumes, and cleanup procedures. Therefore, while the report lists a level below the ML for UF membranes, the ML is the minimum value that is considered a reliable measurement, and the value of 0.00014 µg/L should be understood to indicate that there was 99 percent confidence that there was a greater than zero mercury level, but not taken as a reliable measurement. Hence the value from MF of 0.0055 is a value that can be considered potentially reliable. Additionally, Mercury removal was operating pressure dependent, with higher operating pressure generally resulting in poorer removal of mercury. Note that these were bench-scale test results, not full-scale plant results.

g. Brown and Lester, 1979. Adsorption of mercury is a hypothesized removal mechanism. Note that operating SRT for the activated sludge process was not specified.

h. Olujimi et al., 2012. Note that operating SRT for the activated sludge process was not specified.

i. Pettine et al., 1999. Note this is for lab conditions, not WWTP performance.

j. Andrianisa et al., 2008. Bench-scale study, not WWTP performance.

k. Bolzonella et al., 2010

l. UF/NF/ and RO all produced mercury levels of <0.0013 µg/L

m. Ecology 2010

n. Data from a confidential demonstration project facility using UF/RO/AOP. The filtration process includes MF and UF in parallel, after which the filtrate from each is combined. Degree of removal from each individual process cannot be determined as only influent and final effluent samples were taken for arsenic.

o. Ning, 2002

p. Light, 1981

q. Bhattacharyya et al., 1987

r. Ghosh et al., 1999

s. EPA, 2007

t. Hollerman et al., 1999

u. City of Coeur d'Alene

## 4.3 Unit Processes Selected

The key conclusion from the literature review was that there is limited, to no evidence, that existing treatment technologies are capable of simultaneously meeting all four of the revised standards for the toxics under consideration. Advanced treatment using RO or GAC is expected to provide the best overall removal of the constituents of concern. It is unclear whether these advanced technologies can meet revised effluent limits based on HHWQC, however these processes may achieve the best effluent quality of the technologies reviewed. This limitation in the findings is based on a lack of an extensive dataset on treatment removal effectiveness in the technical literature for the constituents of interest at the low levels relevant to the proposed criteria, which approach or exceed the limits of reliable removal performance for the technologies and analytical methods. As Table 4-2 highlights, certain unit processes are capable of removing a portion, or all, of an individual constituent in each technology. The removal performance for each constituent will vary from facility to facility and require a site-specific, detailed evaluation because the proposed criteria are for such low concentrations. In some cases, a facility may only have elevated concentrations of a single constituent of concern under consideration in this study. In other cases, a discharger may have elevated concentrations of the four constituents identified in this study, as well as others not identified in this study, but subject to revised water quality criteria. This effort is intended to describe a planning level concept of what treatment processes are required to comply with discharge limits for all four constituents. Based on the literature review of unit processes above, four different treatment trains were developed for the analysis that are compared against a baseline of secondary treatment as follows:

- **Baseline:** Conventional secondary treatment is the baseline that is most commonly employed nationwide at wastewater treatment plants. A distinguishing feature for this treatment is the short solids retention time (SRT) (<4 days) in activated slugged that is focused on removal of BOD with minimal removal of the toxic constituents of concern in this study.
- **Advanced Treatment – UF/RO:** This alternative builds on baseline treatment with the implementation of a longer SRT (>8 days) and the addition of UF and RO. The longer SRT removes not only BOD, but it also has the capacity to remove nutrients and a portion of the toxic constituents of concern. This alternative requires a RO brine management strategy which will be discussed in sub-sections below.
- **Advanced Treatment – UF/GAC:** This alternative provides a different approach to advanced treatment by using GAC and avoiding the RO reject brine water management concern. Similar to the UF/RO process, this alternative incorporates the longer SRT (>8 days) with the capacity to remove BOD, nutrients, and a portion of the toxic constituents of concern. As a result, the decision was made to develop costs for advanced treatment options using both RO and GAC.
- **Advanced Treatment – UF/AOP/GAC:** This alternative provides an additional step to advanced treatment with UF/GAC to further enhance effluent quality by

including AOP to break down PCBs and PAH prior to filtration with GAC. Similar to the UF/GAC and UF/RO process options, this alternative includes the longer SRT (>8 days) with the capacity to remove BOD, nutrients, and a portion of the toxic constituents of concern.

- **Advanced Treatment – UF/AOP/GAC/RO:** This alternative provides two additional steps to advanced treatment with UF/GAC to enhance effluent quality even further by including AOP to break down PCBs and PAH prior to filtration with GAC by adding a final step with RO. Similar to the UF/GAC and UF/RO processes, this alternative also includes the longer SRT (>8 days) with the capacity to remove BOD, nutrients, and a portion of the toxic constituents of concern.

The process flowsheets for each alternative are presented in Figure 4-3 to Figure 4-7, beginning with the baseline secondary treatment process in Figure 4-3, followed by the 4 advanced treatment alternatives. Table 4-3 presents a summary of unit process descriptions for the individual elements of each alternative treatment process train. Appendix A presents a summary of the sizing criteria for each of the unit treatment processes.

Table 4-3. Unit Processes Description for Each Alternative

Unit Process	Baseline	Advanced Treatment – UF/GAC	Advanced Treatment – UF/AOP/GAC	Advanced Treatment – UF/RO	Advanced Treatment – UF/AOP/GAC/RO
Influent Flow	5 mgd				
CEPT; Optional	--	Metal salt addition (alum) upstream of primaries			
Activated Sludge	<ul style="list-style-type: none"> <li>HRT: 4 hrs.</li> <li>Short SRT: &lt;8 days</li> </ul>	<ul style="list-style-type: none"> <li>HRT: 9 hrs. (Requires more tankage than the Baseline)</li> <li>Long SRT: &gt;8 days (Requires more tankage than the Baseline)</li> </ul>			
Secondary Clarifiers	Hydraulically Limited				
Ultrafiltration (UF)	--	Membrane Filtration to Remove Particles, Bacteria, Viruses, and some Colloids			
AOP	--	--	Breaks down PCBs and BAPs	--	Breaks down PCBs and BAPs
Reverse Osmosis (RO)	--	--		RO treats 50% of flow to remove metals and dissolved constituents. Sending 50% of flow through the RO and blending it with the balance of plant flows ensures a stable, non-corrosive, non-toxic discharge.	
Reverse Osmosis Brine Reject Mgmt	--	--		Several Options (All Energy or Land Intensive)	
Granular Activated Carbon (GAC)	--	Removes Dissolved Constituents		--	Removes Dissolved Constituents
Disinfection	Not shown to remove any of the constituents				

### 4.3.1 Baseline Treatment Process

A flowsheet of the baseline treatment process is provided in Figure 4-3. The baseline treatment process assumes the current method of treatment commonly employed by wastewater dischargers. For this process, water enters the headworks and undergoes primary treatment, followed by conventional activated sludge (short SRT) and disinfection. The excess solids wasted from the activated sludge process are thickened, followed by mixing with primary solids prior to entering the anaerobic digestion process for solids stabilization. The digested biosolids are dewatered to produce a cake and hauled off-site. Since the exact process for each facility in Washington is unique, this secondary treatment process was used to establish the baseline capital and O&M costs. The baseline costs will be compared against the advanced treatment alternatives to illustrate the magnitude of the increased costs and environmental impacts.

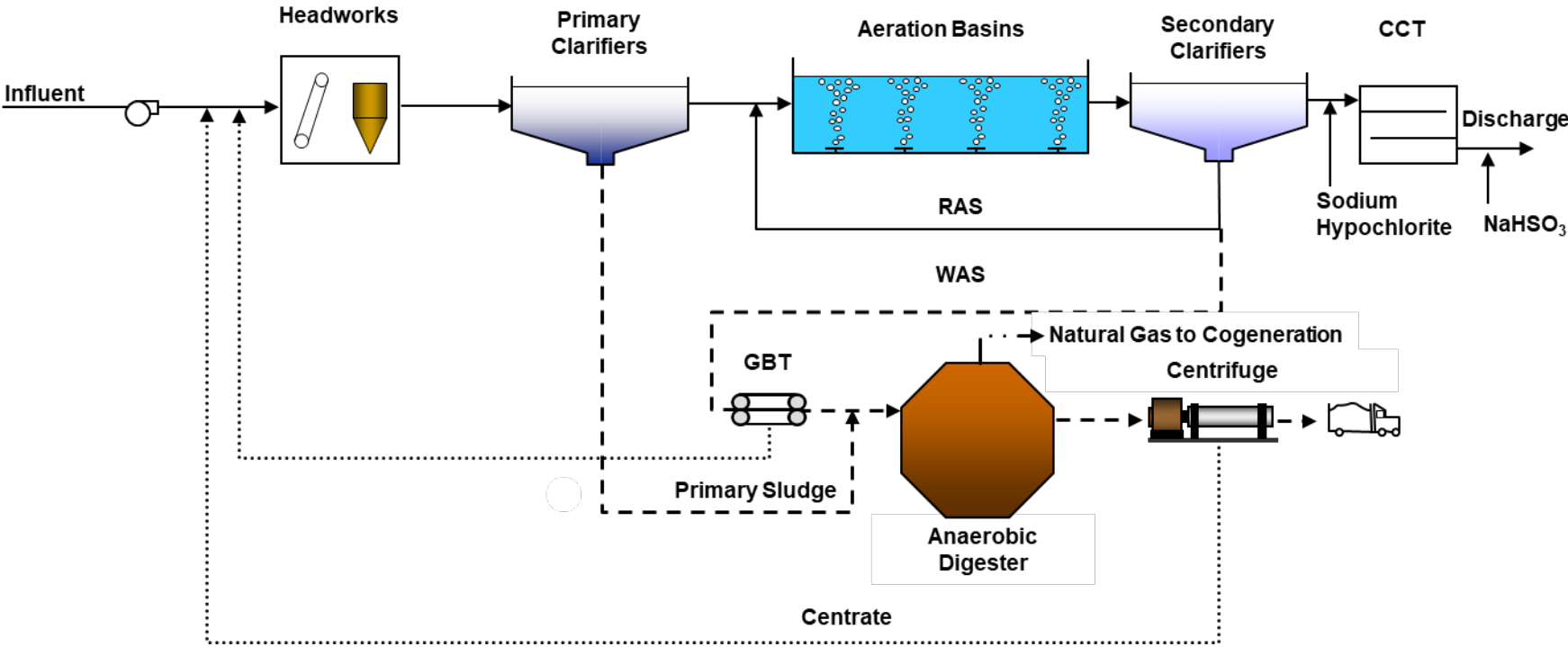

Figure 4-3. Baseline Flowsheet – Conventional Secondary Treatment

### 4.3.2 Advanced Treatment – Tertiary UF/RO

A flowsheet for the advanced treatment Tertiary UF/RO alternative is provided in Figure 4-4. This alternative builds on the baseline secondary treatment facility, whereby the SRT is increased in the activated sludge process, and UF and RO are added prior to disinfection and discharge. The solids treatment train does not change with respect to the baseline. Additionally, a brine management strategy must be included for RO reject.

The longer SRT in an activated sludge plant provides the following benefits:

- Lower effluent BOD and TSS discharge load
- Higher removal of recalcitrant constituents and heavy metals
- Improved water quality and benefit to downstream users
- Less downstream algal growth
- Reduced receiving water dissolved oxygen demand due to ammonia removal
- Reduced ammonia discharge loads, which is toxic to several aquatic species
- Improved water quality for habitat, especially as it relates to biodiversity and eutrophication
- Secondary clarifier effluent more conditioned for filtration and disinfection
- Greater process stability from the anaerobic/anoxic zones serving as a selector

The RO process concentrates contaminants into a smaller volume reject stream. Disposing of the RO reject stream can be challenging because of the potentially large volume of water involved and the concentration of contaminants contained in the brine. For reference, a 5 mgd process wastewater flow might result in 1 mgd of brine reject requiring further management. The available treatment/handling options for RO reject are as follows:

- Brine Recovery Systems
- Surface water discharge
- Ocean discharge
- Haul and discharge to coastal location for ocean discharge
- Sewer discharge
- Deep well injection
- Evaporate in a pond
- Solar pond concentrator

Many of the RO brine reject management options above result in returning the dissolved solids to a “water of the state” such as surface water, groundwater, or marine waters. Past rulings in Washington State have indicated that once pollutants are removed during treatment they are not to be re-introduced to a water of the state. As a result, these

methods for disposal were not considered viable options for management of RO reject water in Washington.

Membrane filtration is a proven technology demonstrated over 35 years of operations. The key technical and operational challenges associated with the tertiary add-on membrane filtration units are as follows:

- Membrane durability is dependent on feed water quality. The feed water quality is facility specific.
- Membranes are sensitive to particles, so upstream screening is critical. The newer generations of membranes have technical specifications that require a particular screen size.
- Membrane area requirements may be based on peak flows as water must pass through the membrane pores. Additionally, membranes struggle with variable hydraulic loading. Flow equalization upstream can greatly reduce the required membrane surface area and provide uniform membrane loading. Flow equalization was assumed for this analysis, however, at certain plants, flow equalization may not be possible and the cost for UF, AOP, GAC, and RO systems will increase significantly as a result.
- Membrane tanks can exacerbate foam related issues from the upstream biological process. Foam entrapment in the membrane tank from the upstream process can reduce membrane filtration capacity and in turn result in a plant-wide foam accumulation problem.
- Reliable access to the membrane modules is key to practical operation and maintenance. Once the automated programmable logical control (PLC) system is functioning properly, overall maintenance requirements for sustained membrane operation are relatively modest.
- Membranes are maintained through frequent membrane relaxation, or back pulses, combined with a periodic deep chemical clean in place (CIP) process.
- Sizing of membrane filtration facilities is governed by hydraulic flux. Municipal wastewater applications are typically based on flux rates that range from about 20 to 40 gallons per square foot per day (gfd) under average annual conditions. The flux associated with industrial applications is wastewater specific.

### Brine Recovery System

A Brine Recovery System (BRS) produces little or no liquid brine residual, but rather leaves a dried residual salt material or low moisture content cake solids to be disposed of in some way. This process improves the water recovery of the RO system by reducing the volume of brine that must be treated and disposed of in some manner. BRS options include intermediate treatment, thermal-based technologies, pressure driven membranes electric potential driven membranes, and other alternative approaches.





## Summary

There are many techniques which can be used to manage reject brine water associated with RO treatment. The selection of an appropriate alternative is primarily governed by geography and local constraints. A comparison of the various brine management methods and relative potential costs are provided in Table 4-4.

Table 4-4. Brine Disposal Method Relative Cost Comparison

Disposal Method	Description	Relative Capital Cost	Relative O&M Cost	Comments
Brine Recovery System (BRS)	Further concentrates brine reject for further downstream processing	High	High	This option is preferred as an intermediate step. This rationale is based on the reduction in brine reject volume to handle following BRS: RO reject stream volume is reduced on the order of 50-90%.
Surface Water Discharge	Brine discharge directly to surface water. Requires an NPDES permit.	Lowest	Lowest	Capital and O&M costs are heavily dependent on the distance from brine generation point to discharge. Not a viable option given that brine contains constituents to be removed from surface waters.
Ocean Discharge	Discharge through a deep ocean outfall. Requires an NPDES permit.	Medium	Low	Capital cost depends on location and availability of existing deep water outfall, or viability of permitting a new marine outfall.
Sewer Discharge	Discharge to an existing sewer pipeline for treatment at a wastewater treatment plant.	Low	Low	Both capital and O&M costs heavily dependent on the brine generation point to discharge distance. Higher cost than surface water discharge due to ongoing sewer connection charges. Viability depends upon whether discharge to another facility is acceptable.
Deep Well Injection	Brine is pumped underground to an area that is isolated from drinking water aquifers.	Medium	Medium	Technically sophisticated discharge and monitoring wells required. O&M cost highly variable based on injection pumping energy.
Evaporation Ponds	Large, lined ponds are filled with brine and as water evaporates, a concentrated salt remains.	Low – High	Low	Capital cost highly dependent on the amount of brine, climate conditions, and the availability and cost of land.
Salinity Gradient Solar Ponds (SGSP)	SGSPs harness solar power from pond to power an evaporative unit.	Low – High	Lowest	Same as evaporation ponds plus added cost of heat exchanger and pumps. Lower O&M cost due to electricity production.

Of the brine management options, BRS was considered as the most viable approach for this analysis to RO reject water management. Two BRS options were examined: a thermal concentrator and a membrane concentrator, both with the same size evaporation pond following BRS. Capital expenditures for the two are similar, but the thermal concentrator has far higher O&M costs. The membrane option was chosen because of more reasonable costs, and because it will require similar maintenance to the RO system itself. The strength in this combination is that BRS reduces the brine reject volume, which in turn reduces the required evaporation pond footprint size. The disadvantage is that evaporation ponds, compared to several other options, require a substantial amount of physical space, which may not be available at existing treatment plant sites. To further reduce pond size, BRS was evaluated assuming the use of mechanical evaporators, resulting in a total pond area of 4 acres for all advanced treatment scenarios utilizing RO. The incorporation of mechanical evaporators is especially important for the state of Washington due to seasonal variations in weather, relatively low evaporation rates, and high precipitation rates in parts of the state. It is also important to recognize that the greenhouse gas (GHG) emissions vary widely for the eight brine management options listed above based on energy and chemical intensity.

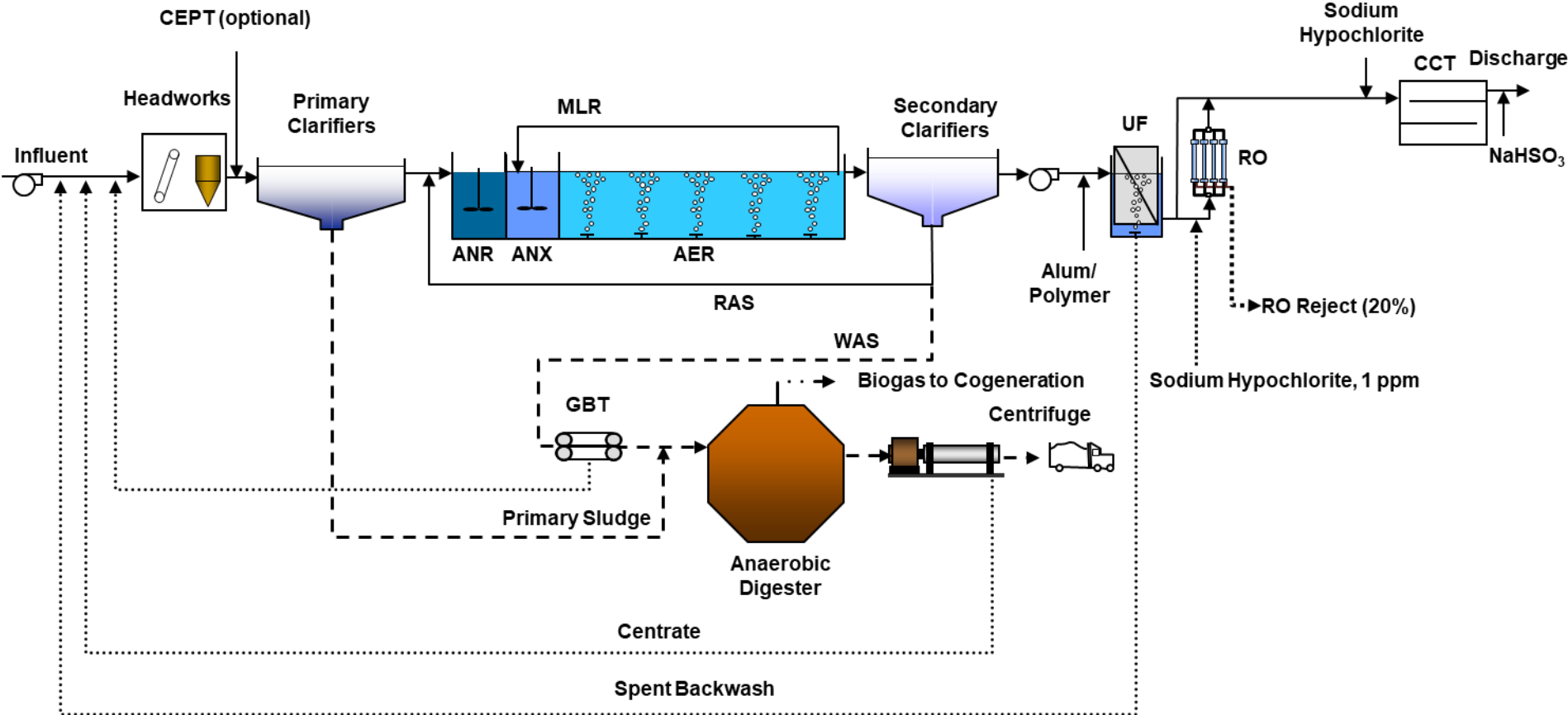

Figure 4-4. Advanced Treatment Flowsheet – Tertiary UF/RO

### 4.3.3 Advanced Treatment – Tertiary UF/GAC Alternative

A flowsheet for the advanced treatment Tertiary UF/GAC alternative is provided in Figure 4-5. Following the UF technology, a GAC contactor and media are required. This alternative was developed as an option that does not require a brine management technology for comparison to the advanced treatment Tertiary UF/RO alternative. However, this treatment alternative does require new or regenerated GAC, and disposal/hauling of spent GAC. A baseline secondary treatment facility can be retrofitted for UF/GAC. The long SRT in an activated sludge plant provides the following benefits, as previously stated:

- Lower effluent BOD and TSS discharge load
- Higher removal of recalcitrant constituents and heavy metals
- Improved water quality and benefit to downstream users
- Less downstream algal growth
- Reduced receiving water dissolved oxygen demand due to ammonia removal
- Reduced ammonia discharge loads, which is toxic to several aquatic species
- Improved water quality for habitat, especially as it relates to biodiversity and eutrophication
- Secondary clarifier effluent more conditioned for filtration and disinfection
- Greater process stability from the anaerobic/anoxic zones serving as a selector

The key technical and operational challenges associated with the tertiary add-on membrane filtration units are as follows:

- Membrane durability is dependent on feed water quality. The water quality is facility specific.
- Membranes are sensitive to particles, so upstream screening is critical. The newer generations of membranes have technical specifications that require a particular screen size.
- Membrane area requirements may be based on peak flows as water must pass through the membrane pores. Additionally, membranes struggle with variable hydraulic loading. Flow equalization upstream can greatly reduce the required membrane surface area and provide uniform membrane loading. Flow equalization was assumed for this analysis, however at certain plants, flow equalization may not be possible and the cost for UF, AOP, GAC, and RO systems will significantly increase.
- Membrane tanks can exacerbate any foam related issues from the upstream biological process. Foam entrapment in the membrane tank from the upstream process can reduce membrane filtration capacity and in turn result in a plant-wide foam problem.

- Once the automated programmable logical control (PLC) system is functioning, overall maintenance requirements for sustained membrane operation are relatively modest.
- Membranes are maintained through frequent membrane relaxation, or back pulses, combined with a periodic deep chemical clean in place (CIP) process.
- Sizing of membrane filtration facilities is governed by hydraulic flux. Municipal wastewater characteristics result in flux values that range from about 20 to 40 gallons per square foot per day (gfd) under average annual conditions. The flux associated with industrial applications may vary and is wastewater specific.

Following the UF membranes are the activated carbon facilities. There are two kinds of activated carbon used in treating water: powdered activated carbon (PAC) and GAC. PAC is finely-ground, loose carbon that is added to water, mixed for a short period of time, and removed. GAC is larger than PAC, is generally used in beds or tanks that permit higher adsorption and easier process control than PAC allows and is replaced periodically. PAC is not selective, and therefore, will adsorb all active organic substances making it an impractical solution for a wastewater treatment plant. As a result, GAC was considered for this analysis. The type of GAC (e.g., bituminous and subbituminous coal, wood, walnut shells, lignite or peat), gradation, and adsorption capacity are determined by the size of the largest molecule/contaminant that is being filtered (AWWA, 1990).

GAC is employed in two fashions, either in gravity contact basins, or in pressurized tanks. Pressurized tanks are more commonly used in polishing applications, such as the removal of trace amounts of our constituents of concern.

As water flows through the carbon bed, contaminants are captured by the surfaces of the pores until the carbon is no longer able to adsorb new molecules. The concentration of the contaminant in the treated effluent increases over time. Once the contaminant concentration in the treated water reaches an unacceptable level (called the breakthrough concentration), the carbon is considered "spent" and must be replaced by virgin or reactivated GAC.

The capacity of spent GAC can be restored by thermal reactivation. Some treatment facilities have the ability to regenerate GAC on-site, but generally small systems haul the spent GAC away for off-site regeneration (EPA 1993). For this study, off-site disposal was assumed.

The basic facilities and unit processes included in this treatment process alternatives with GAC are as follows:

- GAC supply and delivery
- GAC influent feed (Secondary Effluent) pumping
  - Low head feed pumping
  - High head feed pumping (assumed for this study for pre-engineered pressure GAC contactors)
- Contactors and backwash facilities
  - Custom gravity GAC contactor

- Pre-engineered pressure GAC contactor (assumed for this study)
  - Backwash pumping
- Storage facilities
  - Steel tanks
  - Concrete tanks (assumed for this study; larger plants would typically select concrete tanks)
- Spent carbon regeneration
  - On-site GAC regeneration
  - Off-Site GAC regeneration/disposal (disposal assumed for this study)

The GAC contactor provides a 25-minute empty bed contact time (EBCT) for maximum month conditions. The GAC media must be regenerated/changed out about twice per year in a furnace. The constituents sorbed to the GAC media are removed during the regeneration process. A typical design has full redundancy and additional storage tankage for spent and virgin GAC. Facilities that use GAC need to decide whether they will regenerate GAC on-site or off-site. Due to challenges associated with receiving air emission permitting for new furnaces, it was assumed that off-site regeneration/disposal was the more likely option and included for this analysis.

The key technical and operational challenges associated with the tertiary add-on GAC units are as follows:

- Nearest vendor to acquire virgin GAC supplies. Frequency of virgin GAC delivery and hauling costs.
- Contactor selection is typically based on existing treatment plant equipment, as well as available operator expertise and labor-hours. Concrete gravity contactors are not typically used for polishing applications compared with pre-engineered pressure filters, and pressure filters can handle a wider range of flows. Gravity concrete filters may be feasible when converting pre-existing conventional filters at a treatment plant, but otherwise take longer to design and construct. Furthermore, gravity concrete filters require far greater operations and maintenance effort compared to pressure contactors for a variety of reasons; gravity GAC contactors are subject to biological growth issues, have a more complex media replacement process, and are more difficult to repair. Installment of prefabricated pressure vessels is simpler, and because they are standard across most installations, they require less operator training. For these reasons, the gravity GAC contactor was not used for this evaluation.
- Periodic backwashing is critical for maintaining the desired hydraulics and to control biological growth.
- Off-site GAC regeneration/disposal appears more viable due to the challenges with air emissions permitting and was assumed for this study

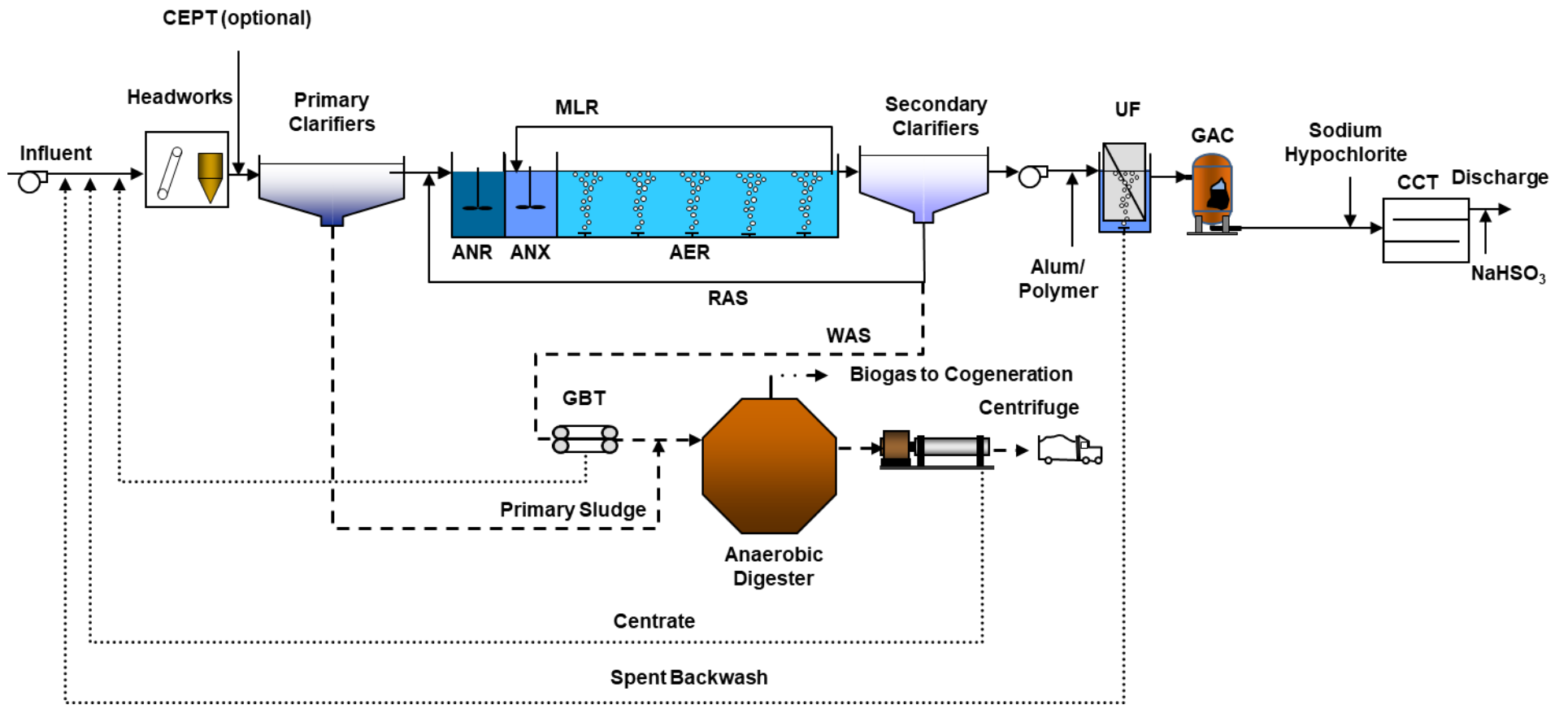

Figure 4-5. Advanced Treatment Flowsheet – Tertiary UF/GAC



#### 4.3.4 Advanced Treatment – Tertiary UF/AOP/GAC

A flowsheet of the advanced treatment Tertiary UF/AOP/GAC alternative is provided in Figure 4-6. Following the UF technology, AOP is used for breakdown of PCBs and BAPs, followed by GAC pressure contactors to remove the remaining contaminants. This alternative was developed in order to focus on further reduction of PCBs and BAPs to levels lower than possible with UF and GAC alone, by breaking down the contaminants and adsorbing the remnants in GAC.

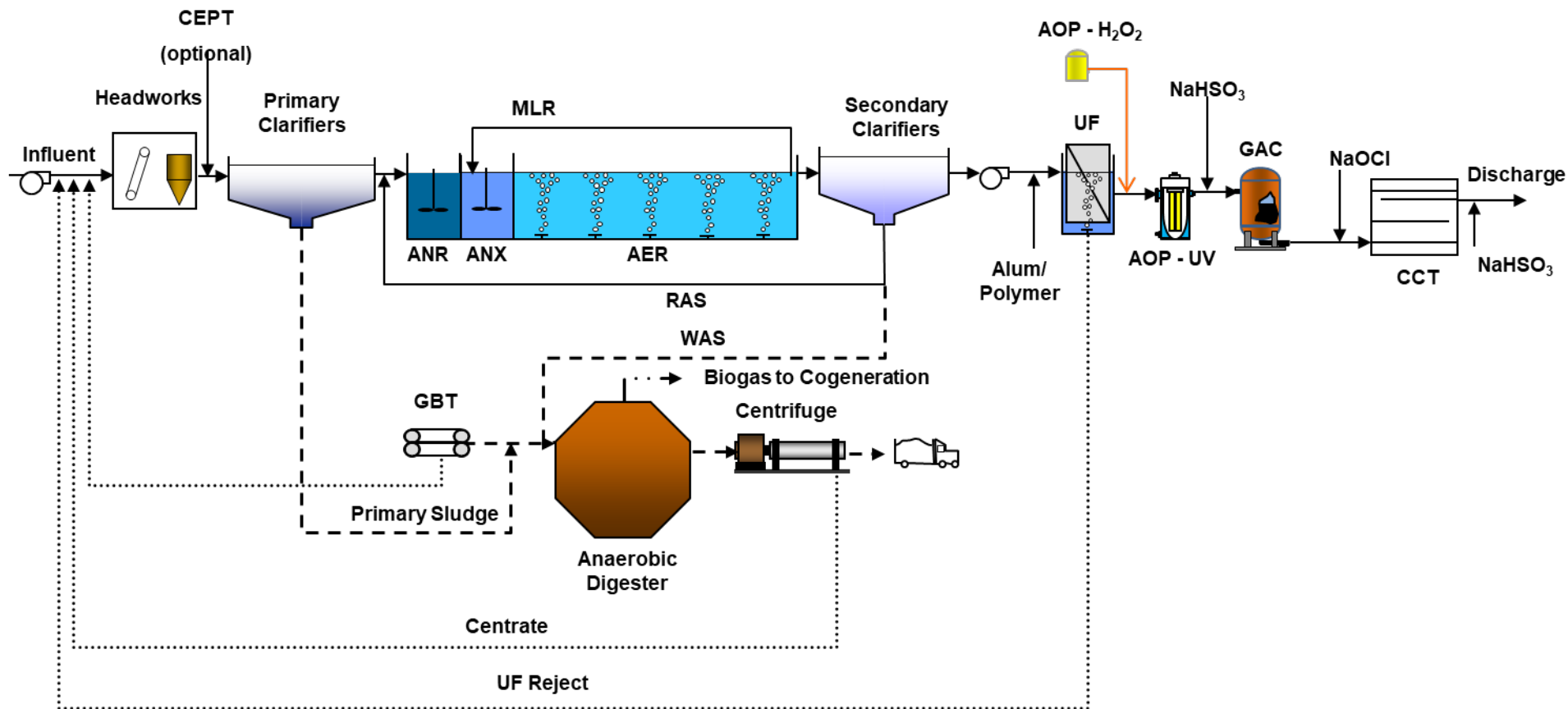

Figure 4-6. Advanced Treatment Flowsheet – Tertiary UF/AOP/GAC



#### 4.3.5 Advanced Treatment – Tertiary UF/AOP/GAC/RO

A flowsheet of the advanced treatment Tertiary UF/AOP/GAC/RO alternative is provided in Figure 4-7. Following the UF technology, AOP is used for breakdown of PCBs and BAPs, followed by GAC pressure contactors to remove the remaining contaminants. RO is added to this process train in order to further reduce all targeted contaminants: Arsenic, BAP, Mercury and PCBs. This alternative was developed in order to reduce PCBs and BAPs to lower levels than possible with UF, AOP and GAC, by breaking down the contaminants and removing them in GAC with further final filtration through RO.

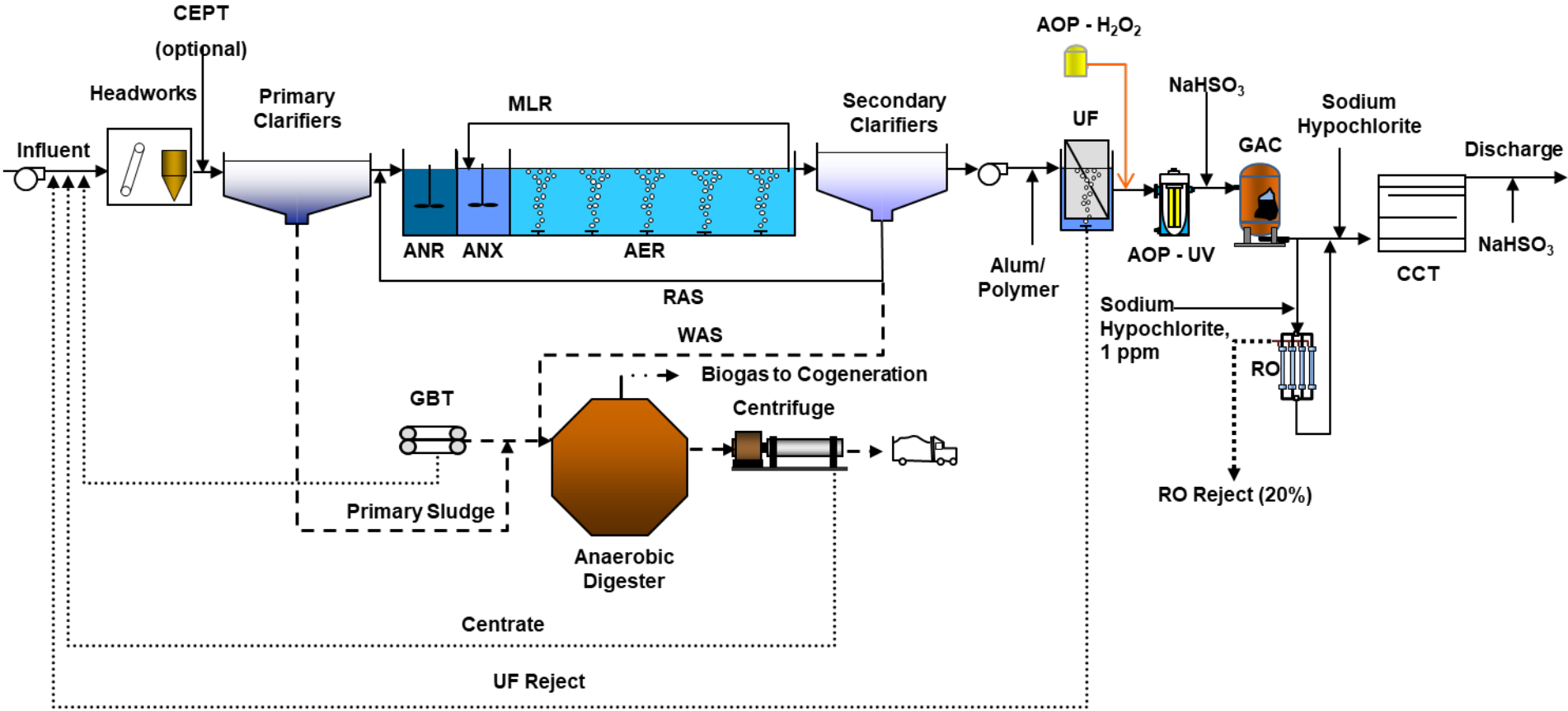

Figure 4-7. Advanced Treatment Flowsheet – Tertiary UF/AOP/GAC/RO

## 4.4 Steady-State Mass Balance

A steady-state mass balance program was used to calculate the flows and loads within the candidate advanced treatment processes in order to size facilities. The design of wastewater treatment facilities is generally governed by steady-state mass balances. For a steady-state mass balance, the conservation of mass is calculated throughout the entire wastewater treatment facility for defined inputs. Dynamic mass balance programs exist for designing wastewater facilities, but for a planning level study such as this, a steady-state mass balance program is adequate. A dynamic program is generally used for detailed design and is site-specific with associated requirements for more detailed wastewater characterization.

The set of model equations used to perform a steady-state mass balance are referred to as the model. The model equations provide a mathematical description of various wastewater treatment processes, such as an activated sludge process, that can be used to predict unit performance. The program relies on equations for each unit process to determine the flow, load, and concentration entering and leaving each unit process.

An example of how the model calculates the flow, load, and concentration for primary clarifiers is provided below. The steady-state mass balance equation for primary clarifiers has a single input and two outputs as shown in the simplified Figure 4-8. The primary clarifier feed can exit the primary clarifiers as either effluent or sludge. Solids not removed across the primaries leave as primary effluent, whereas solids captured leave as primary sludge. In this example, scum is not accounted for.

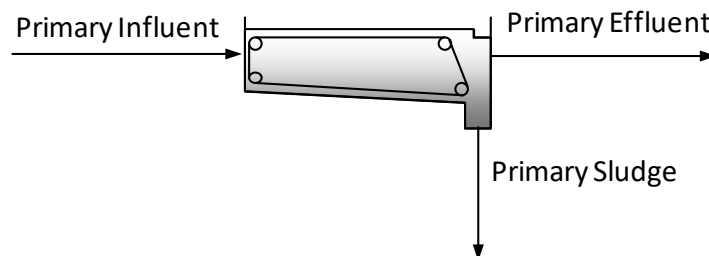

**Figure 4-8. Primary Clarifier Inputs/Outputs**

The mass balance calculation for a primary clarifier requires the following input:

- Solids' removal percentage across the primaries (based on average industry accepted performance)
- Primary solids thickness (i.e., percent solids) (based on average industry accepted performance)

The steady-state mass balance program provides a reasonable first estimate for the process performance, and an accurate measure of the flows and mass balances at various points throughout the plant. The mass balance results were used for sizing the facility needs for each alternative. A listing of the unit process sizing criterion for each unit process is provided in Appendix A. By listing the unit process sizing criteria, a third-

party user can replicate the analysis and arrive at comparable results. The key sizing criteria that differ between the baseline and treatment alternatives are as follows:

- Aeration basin size for baseline was based on MLSS whereas for advanced treatment alternatives it is based on oxygen uptake rate (OUR).
- The UF/GAC, UF/AOP/GAC, UF/RO and UF/AOP/GAC/RO sizing is only required for the respective advanced treatment alternatives.

## 4.5 Adverse Environmental Impacts Associated with Advanced Treatment Technologies

The transition from the baseline (conventional secondary treatment) to the advanced treatment alternatives has some environmental impacts that merit consideration, including the following:

- Land area for additional system components (which for constrained facility sites may necessitate land acquisition and encroachment into neighboring properties with associated issues and challenges, etc.).
- Increased energy use and atmospheric emissions of greenhouse gases and criteria air contaminants associated with power generation to meet new pumping requirements across the membrane filter systems (UF and RO) and GAC.
- Increased chemical demand associated with membrane filters (UF and RO).
- Increased chemical demand associated with AOP
- Energy and atmospheric emissions associated with granulated charcoal regeneration.
- RO brine reject disposal. The brine recovery systems are energy intensive and increase atmospheric emissions as a consequence of the electrical power generation required for removing water content from brine reject.
- Increase in sludge generation from transitioning from the baseline to the advanced treatment alternatives. There will be additional sludge captured with the chemical addition to the primaries and membrane filters (UF and RO). Additionally, the GAC units will capture more solids.
- Benefits to receiving water quality by transitioning from a short SRT (<4 days) in the baseline to a long SRT (>8 days) for the advanced treatment alternatives (as previously stated):
  - Lower BOD and TSS discharge loads
  - Higher removal of recalcitrant constituents and heavy metals
  - Improved water quality and benefit to downstream users
  - Reduced nutrient loadings to receiving waters and lower algal growth potential

- Reduced in receiving water body's dissolved oxygen depression due to ammonia removal
- Reduced ammonia discharge loads, which is toxic to aquatic species
- Improved water quality for aquatic habitat, especially as it relates to biodiversity and eutrophication
- Secondary clarifier effluent better conditioned for subsequent filtration and disinfection
- Greater process stability from the anaerobic/anoxic zones serving as biological selectors

GHG emissions were calculated for the baseline and advanced treatment alternatives. The use of GHG emissions is a tool to normalize the role of energy, chemicals, biosolids hauling, and fugitive emissions (e.g., nitrous oxide and methane) in a single unit. The mass balance results were used to quantify energy demand and the corresponding GHG emissions for each alternative. Energy demand was estimated from preliminary process calculations.

A listing of the energy demand for each process stream, the daily energy demand, and the unit energy demand is presented in Table 4-5. The negative energy demand for the solids stream in Table 4-5 represents the recovery of biogas from the anaerobic treatment process and utilization for as fuel for cogeneration of electrical power and heat. The 1,110 kWh/MG treated for the baseline is relatively close to other industry unit energy benchmarks (Gu et al., 2017). An adapted plot from the Gu et al. (2017) study is provided in Figure 4-9, which suggests that a 5 mgd plant with activated sludge requires on the order of 1,500 kWh/MG treated. The difference between the two estimates is likely attributed to a lack of anaerobic digestion and cogeneration for a 5 mgd plant and other miscellaneous differences as captured in the Gu et al. (2017) study. If Gu et al. (2017) study excluded such facilities, the unit energy demand would be on the order of 1,300 kWh/MG treated.

The advanced treatment options energy demand ranges from 2.0 to 2.8 times greater than the baseline. This large increase in energy demand is attributed to the energy required to pass water through the membrane barriers and/or the granular activated carbon. This increase aligns with findings from both Falk et al. (2011) and USEPA (2021) that evaluated various tiers of nutrient levels with the results also suggesting increases 2+ times with the most stringent requiring advanced treatment (e.g., RO). Additionally, there is energy required to handle the constituents removed as either regenerating/disposing of the GAC or handling the RO brine reject water. This additional energy required to treat the removed constituents is presented in Table 4-5.

Details on the assumptions used to convert between energy demand, chemical demand and production, as well as biologically-mediated gases (i.e., CH<sub>4</sub> and N<sub>2</sub>O) and GHG emissions are provided in Appendix B.

A plot of the GHG emissions for each alternative is shown in Figure 4-10. The GHG emissions increase from the baseline to progressively higher levels for each of the advanced treatment alternatives. The GHG emissions increase approximately 100

percent with respect to baseline for the UF/GAC alternative process and over 116 percent for the UF/RO alternative.

**Table 4-5. Energy Breakdown for Each Alternative (5 mgd design flow)**

Parameter	Units	Baseline	Advanced Treatment – Tertiary UF/GAC	Advanced Treatment – Tertiary UF/AOP/GAC	Advanced Treatment – Tertiary UF/RO	Advanced Treatment – Tertiary UF/AOP/GAC/RO
Daily Liquid Stream Energy Demand	MWh/d	6.5	12.2	12.9	13.0	16.8
Daily Solids Stream Energy Demand <sup>a</sup>	MWh/d	-1.0	-0.9	-0.9	-0.9	-0.9
Daily Energy Demand	MWh/d	5.6	11.3	12.1	12.1	15.9
Unit Energy Demand	kWh/MG Treated	1,100	2,300	2,400	2,400	3,200

<sup>a</sup> The solids stream energy results in a net production of energy from anaerobic digestion cogeneration.

MWh/d = megawatt hours per day  
 kWh/MG = kilowatt hours per million gallons

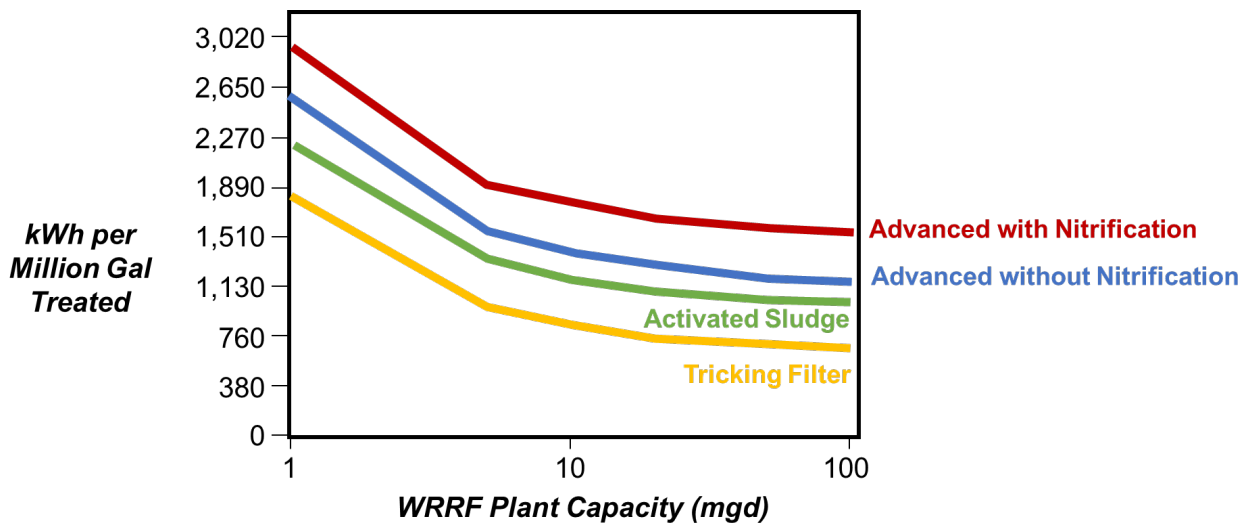

**Figure 4-9. Example of an Energy Benchmark (Source: Gu et al., 2017)**

The UF/GAC energy demand would be larger if GAC regeneration was performed on-site at the treatment facility versus off-site regeneration/disposal at a vendor’s facility located elsewhere. The GHG emissions presented in Figure 4-10 do not include the energy or air emissions that result from off-site GAC regeneration. Only the hauling associated with



transporting the spent GAC is included. The energy associated with operating the spent carbon regeneration furnace would exceed the GHG emissions from hauling spent GAC to a remote site for regeneration.

The BRS liquid discharge portion of GHG emissions alone in the UF/RO and UF/AOP/GAC/RO alternatives are comparable to the baseline level of GHGs. This contribution to increased GHG emissions by the BRS highlights the importance of the challenges associated with managing brine reject.

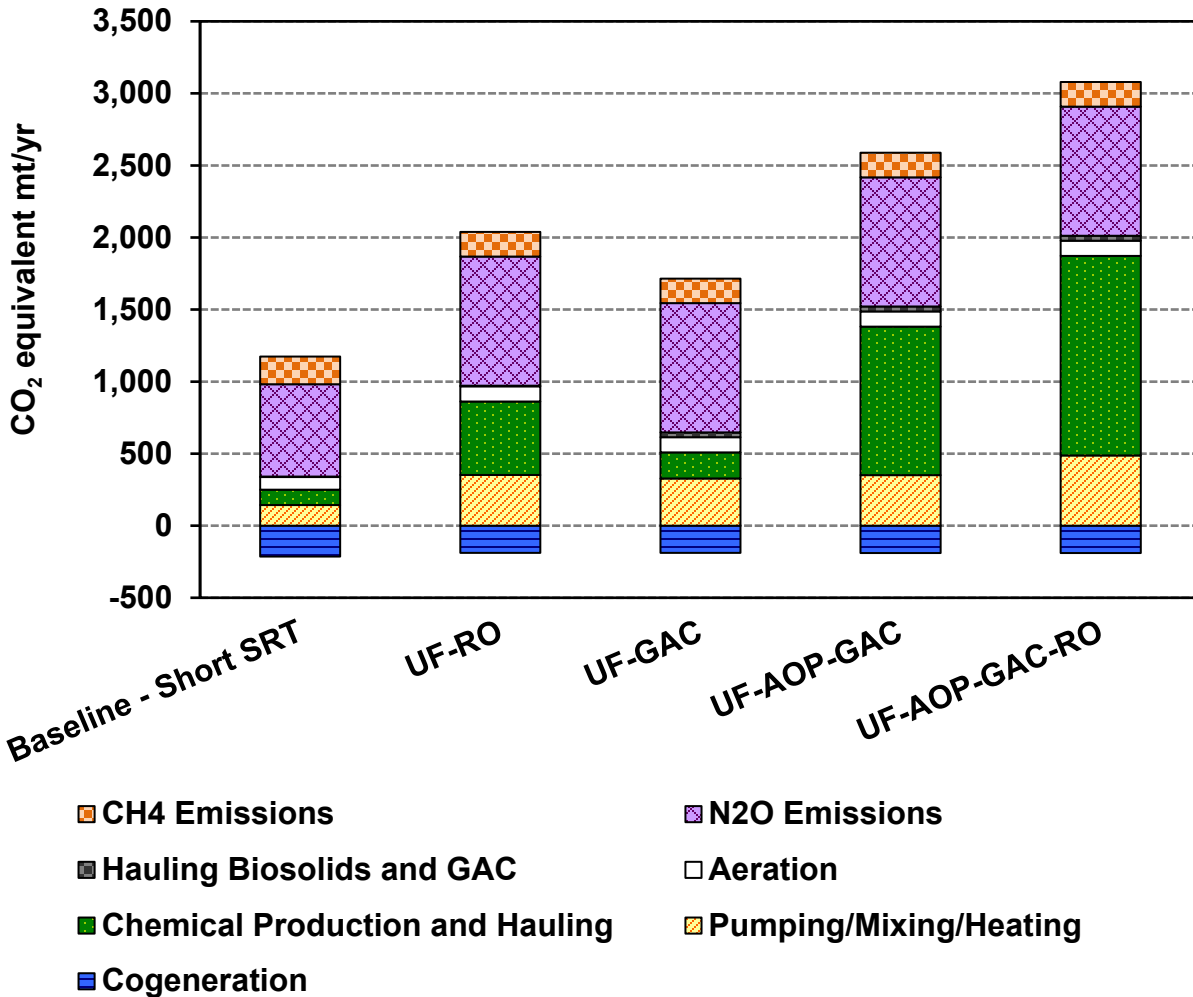

Figure 4-10. Greenhouse Gas Emissions for Each Alternative

The use of GHG emissions as a measure of sustainability does not constitute a complete comparison between the baseline and advanced treatment alternatives. Rather, it is one metric that captures the impacts of energy, chemical demand, and production, as well as biologically mediated gases (i.e., CH<sub>4</sub> and N<sub>2</sub>O). The GHG emissions results suggests that careful consideration should be given to the benefits from advanced treatment compared to the potential adverse environmental impacts and economic costs.

An example list of other potential environmental impacts to consider are as follows based on the Tool for the Reduction and Assessment of Chemical and Environmental Impacts (TRACI; Bare et al., 2003; Bare, 2011) as described in a recent EPA publication (EPA, 2021):

- Eutrophication potential
- Cumulative energy demand
- Global warming potential via GHG emissions (as presented in this effort)
- Acidification potential
- Fossil depletion
- Smog formation potential
- Human health – particulate matter formation
- Ozone depletion potential
- Water depletion
- Human health toxicity – cancer potential
- Human health toxicity – noncancer potential
- Ecotoxicity potential

This effort excluded the majority of these considerations since this planning level evaluation focused on the energy and chemical impacts via demands, costs, and GHG emissions. The incorporation of such parameters to inform decision-making might be worthwhile if dischargers are required to move forward with such treatment considerations.

## 4.6 Costs

Total project costs, along with the operations and maintenance costs, were developed for each advanced treatment alternative for a comparison with baseline secondary treatment.

### 4.6.1 Approach

The cost estimates presented in this report are planning level opinions of probable construction costs for a nominal 5 mgd treatment plant design flow representing a typical facility without site specific details about local wastewater characteristics, physical site constraints, existing infrastructure, receiving waters, etc. The cost estimates are based on wastewater industry cost references, technical studies, actual project cost histories, and professional experience. The costs presented in this report are considered planning level estimates. A more detailed development of the advanced treatment process alternatives and site-specific information would be required to further refine the cost estimates. Commonly, this is accomplished in the preliminary design phase of project development for specific facilities following planning phases.

The cost opinion includes a range of costs associated with the level of detail used in this analysis. Cost opinions based on preliminary engineering can be expected to follow the Association for the Advancement of Cost Engineering (AACE International) Recommended Practice No. 17R-97 Cost Estimate Classification System estimate Class 5. A Class 5 estimate is based upon a 0 to 2 percent project definition, commensurate with a master plan of concept design. A Class 5 estimate has an expected accuracy range of -35 to 60 percent. It is considered an “order-of-magnitude estimate.” The life-cycle costs were prepared using the net present value (NPV) method.

The cost associated for each new unit process is based on a unit variable, such as required footprint, volume, demand (e.g., lb O<sub>2</sub>/hr), and others. This approach is consistent with the approach developed for the EPA document titled “Estimating Water Treatment Costs: Volume 2-Cost Curves Applicable to 1 to 200 mgd Treatment Plants” dated August 1979. The approach has been updated since 1979 to account for inflation and competition, but the philosophy for estimating costs for unit processes has not changed. For example, the aeration system sizing/cost is governed by the maximum month airflow demand. Additionally, the cost associated with constructing an aeration basin is based on the volume. The cost estimates consider economies of scale.

The O&M cost estimates were calculated from preliminary process calculations. The operations cost includes energy, chemical demand, and labor. For example, a chemical dose was assumed based on industry accepted dosing rates and the corresponding annual chemical cost for that chemical. The maintenance cost values account for labor, equipment replacement, and in particular membrane and UV lamp replacement for the advanced treatment alternatives.

#### 4.6.2 Unit Cost Values

The life-cycle cost evaluation was based on using the economic assumptions shown in Table 4-6. The chemical costs were based on actual values from other projects. To perform detailed cost evaluations, each selected technology would need to be arranged on a site-specific facility plan based on the location of the existing piping, channels, and other necessary facilities.

Table 4-6. Economic Evaluation Variables

Item	Value
Nominal Discount Rate	5%
<b>Financial Parameters:</b>	
Base Year	2022
Project Life	20 years
Energy	\$0.10/kWh
Natural Gas	\$9/1000 ft <sup>3</sup>
<b>Chemicals:</b>	
Alum (44-49%)	\$0.87/gal
Ferric Chloride	\$1,218/ton
Sodium Hypochlorite (12.5%)	\$1.4/gal
Sodium Bisulfite (25%)	\$1.53/gal
Hydrogen Peroxide (50%)	\$2.50/Gal
Anti-Scalant	\$2.90/lb
Salt	\$0.05/lb
Sulfuric Acid (93%)	\$0.05/lb
Caustic (50%)	\$0.15/lb
<b>Hauling:</b>	
Biosolids Hauling Distance	100 miles (one way)
Biosolids Truck Volume	6,000 gal/truck
Biosolids Truck Hauling	\$100 service fee + \$3.50/mile
GAC Virgin Media Cost	\$45.51/CF
GAC Exchange Cost (removal, disposal, install new media)	\$8.43/CF
kWh= kilowatt hours; lbs=pounds; GAC=granulated activated carbon; gal=gallon	

### 4.6.3 Net Present Value of Total Project Costs and Operations and Maintenance Cost in 2022 Dollars

An estimate of the net present value for the baseline treatment process and the incremental costs to implement the advanced treatment alternatives is shown in Table . The cost for the existing baseline treatment process was estimated based on new construction for the entire conventional secondary treatment process (Figure 4-3). For comparison with other references, Falk et al. (2011) identified the cost for baseline and advanced treatment with tertiary UF/RO as \$12/gpd and \$29/gpd respectively for a 10 mgd facility in 2020 dollars. These unit cost values would be expected increase from a 10 to a 5 mgd facility as economies of scale are reduced, resulting in higher costs for the 5 mgd facility. The incremental cost to expand from existing baseline secondary treatment to advanced treatment was calculated by taking the difference between the baseline and the advanced treatment alternatives. These values serve as a benchmark for understanding the prospective cost for constructing advanced treatment at the planning level of process development.

**Table 4-7. Treatment Technology Total Project Costs in 2022 Dollars for a 5 mgd Facility**

Alternative	Total Construction Cost (\$ Million)	O&M Net Present Value (\$ Million)**	Total Net Present Value (\$ Million)	NPV Unit Cost, (\$/gpd)
Baseline (Conventional Secondary Treatment)	72 - 178	8 - 19	80 - 197	16 - 39
Advanced Treatment - UF/RO*				
Baseline (from the top of the table)	72 - 178	8 - 19	80 - 197	16 - 39
Additional Cost (beyond Baseline) for UF/RO*from Baseline	75 - 185	21 - 51	96 - 237	19 - 47
Total Cost (includes Baseline): Advanced Treatment - UF/RO*	148 - 364	29 - 70	176 - 434	35 - 87
Advanced Treatment - UF/GAC				
Baseline (from the top of the table)	72 - 178	8 - 19	80 - 197	16 - 39
Additional Cost (beyond Baseline) for UF/GAC	52 - 128	22 - 54	74 - 182	15 - 36



Alternative	Total Construction Cost (\$ Million)	O&M Net Present Value (\$ Million)**	Total Net Present Value (\$ Million)	NPV Unit Cost, (\$/gpd)
Total Cost (includes Baseline): Advanced Treatment - UF/GAC	125 - 307	29 - 72	154 - 379	31 - 76
Advanced Treatment - UF/AOP/GAC				
Baseline (from the top of the table)	72 - 178	8 - 19	80 - 197	16 - 39
Additional Cost (beyond Baseline) for UF/AOP/GAC	66 - 162	31 - 76	97 - 239	19 - 48
Total Cost (includes Baseline): Advanced Treatment - UF/AOP/GAC	138 - 340	39 - 95	177 - 435	35 - 87
Advanced Treatment - UF/AOP/GAC/RO*				
Baseline (from the top of the table)	72 - 178	8 - 19	80 - 197	16 - 39
Additional Cost (beyond Baseline) for UF/AOP/GAC/RO*	117 - 289	47 - 116	164 - 405	33 - 81
Total Cost (includes Baseline): Advanced Treatment - UF/AOP/GAC/RO*	190 - 467	55 - 135	244 - 602	49 - 120

\*Assumes BRS for RO brine management, followed by evaporation ponds. Other options are available as listed in Section 4.3.2

\*\*Includes the cost for labor.

mgd=million gallons per day

MG=million gallons

MF/RO=membrane filtration/reverse osmosis

MF/GAC=membrane filtration/granulated activated carbon

O&M=operations and maintenance

Net Present Value = total financed cost assuming a 5 percent nominal discount rate over an assumed 20-year equipment life.

#### 4.6.4 Unit Cost Assessment

Costs presented above are based on a treatment capacity of 5.0 mgd, however, existing treatment facilities range dramatically across Washington in size and flow treated. Table 4-10 indicates that the unit capital cost for baseline conventional secondary treatment for 5 mgd ranges between \$16 to \$39 per gallon per day of treatment capacity. The unit cost for the advanced treatment alternatives increases the range from the low \$30's to \$120 on a \$/gpd of treatment capacity. The increase in cost for the advanced treatment alternatives is discussed in the sub-sections below.

##### Advanced Treatment – Tertiary UF/RO

The advanced treatment Tertiary UF/RO alternative has a total NPV unit cost range of \$35 to \$87 per gallon per day of capacity. This translates to an incremental cost increase with respect to the baseline of \$19 to \$47 per gallon per day treatment capacity. The key differences in cost between the baseline and the advanced treatment Tertiary UF/RO are as follows:

- Larger aeration basins than the baseline to account for the longer SRT (<4 days versus >8 days).
- Additional pumping stations to pass water through the membrane facilities (UF and RO). These are based on max month flows.
- Equalization Basin.
- Membrane facilities (UF and RO; equipment, tanks chemical feed facilities, pumping, etc.) and replacement membrane equipment.
- Additional energy and chemical demand to operate the membrane facilities (UF and RO).
- Brine Recovery System facilities to further concentrate the brine reject.
- Brine Recovery System facilities are energy/chemically intensive and they require membrane replacement every few years due to the brine reject water quality.
- An evaporation pond to handle the brine reject that has undergone further concentration by the Brine Recovery System.

The advanced treatment Tertiary UF/RO assumes that 100 percent of the flow is treated by UF, followed by 50 percent of the flow treated with RO. Sending a portion of flow through the RO and blending it with the balance of plant flows ensures a stable water (e.g. balanced mineral and chemical content) to discharge to surface waters. The RO brine reject (about 1.0 mgd) undergoes BRS pre-treatment that further concentrates the brine reject to about 0.01 to 0.1 mgd. The recovery for both RO and BRS processes is highly dependent on water quality (e.g., silicate levels).

BRS technologies are effective at concentrating brine reject, but it comes at a substantial cost (\$15 per gallon per day at maximum month influent flow (6.25 mgd)). The ability to further concentrate brine reject was critical from a management standpoint. Although 8

different options were presented for managing brine reject in Section 4.3.1, none of them is an attractive approach for handling brine reject except for BRS. BRS provides a viable pre-treatment step that requires subsequent downstream treatment to further reduce volumes. Evaporation ponds following BRS were used for this study. Without BRS, the footprint space requirements would be much greater.

Approximately 4 acres of evaporation ponds, or more, may be required to handle the BRS concentrate, depending upon concentrator effectiveness, local climate conditions, residuals accumulation, residual removal, etc. Precipitation throughout Washington is highly variable, which can greatly influence evaporation pond footprint space requirements.

Past discussions with an industry installing evaporation ponds revealed that they will use mechanical evaporators to enhance evaporation rates. The use of mechanical evaporators was included in this study and the costs are included in the BRS estimates. Since evaporation rates vary in Washington and are low or vary seasonally, the need for mechanical evaporators will depend on facility location.

### Advanced Treatment – Tertiary UF/GAC

The advanced treatment Tertiary UF/GAC alternative has a total NPV unit cost range of \$31 to \$76 per gallon per day capacity. This translates to an incremental cost increase with respect to the baseline of \$15 to \$36 on a per gallon per day of treatment capacity basis. The key differences in cost between the baseline and the advanced treatment Tertiary UF/GAC are as follows:

- Larger aeration basins than the baseline to account for the longer SRT (<4 days versus >8 days).
- Additional pumping stations to pass water through the UF membrane and GAC facilities. These are based on max month flows.
- Equalization Basin.
- GAC facilities (equipment, pre-engineered pressure contact tanks, pumping, GAC media, etc.)
- Additional energy to feed and backwash the GAC facilities.
- GAC media replacement was the largest contributor of any of the costs.
- Additional hauling and fees to regenerate/dispose of GAC off-site.

The advanced treatment Tertiary UF/GAC assumes that 100 percent of the flow is treated by UF, followed by 100 percent of the flow treated with GAC. The GAC technology is an established technology. The costing approach was in accordance with EPA guidelines developed in 1998.

The critical issue in estimating the cost of the GAC technology is whether a GAC vendor regeneration facility is located within the region. On-site regeneration is an established technology with a furnace, however there are several concerns as listed in Section 4.3.3:

- Ability to obtain an air emissions permit



- Additional equipment to operate and maintain
- Energy and air emissions to operate a furnace on-site
- Operational planning to ensure that furnace is operating 90 to 95 percent of the time. Otherwise, operations will be constantly starting/stopping the furnace which is energy intensive and deleterious to equipment
- If not operated properly, the facility has the potential to create hazardous/toxic waste to be disposed

If located within a couple of hundred miles, off-site GAC regeneration is preferred. For this study, off-site disposal and virgin media replacement was assumed at a cost of \$45.51/cf for new media and \$8.43/cf for removal, disposal, and installation of the new media.

### Advanced Treatment – Tertiary UF/AOP/GAC

The advanced treatment Tertiary UF/AOP/GAC alternative has a total NPV unit cost range of \$35 to \$87 per gallon per day capacity. This translates to an incremental cost increase with respect to the baseline of \$19 to \$48 per gallon per day of treatment capacity basis. As this alternative includes a treatment process added on to the UF/GAC option, the key differences between baseline and the UF/GAC option also apply here but are not listed; the following key differences in cost between UF/GAC and UF/AOP/GAC are as follows:

- Additional chemical feed facilities for Hydrogen Peroxide and Sodium Bisulfite
- Enclosed UV reactors, electrical equipment, and additional piping

The advanced treatment Tertiary UF/AOP/GAC assumes that 100 percent of the flow is treated by the UF, AOP and GAC.

### Advanced Treatment – Tertiary UF/AOP/GAC/RO

The advanced treatment Tertiary UF/AOP/GAC/RO alternative has a total present worth unit cost range of \$49 to \$120 per gallon per day capacity. This translates to an incremental cost increase with respect to the baseline of \$33 to \$81 per gallon per day of treatment capacity basis. As this alternative combines GAC and RO and includes an AOP, the key differences between baseline and the UF/GAC and UF/RO options also apply here but are not listed. The key differences in cost between UF/AOP/GAC and UF/AOP/GAC/RO are as follows:

- Additional pumping stations to pass water through the RO membranes. These are based on maximum month flows.
- RO membrane facilities: equipment, tanks chemical feed facilities, pumping, etc., and replacement membrane equipment.
- Additional energy and chemical demand to operate the RO membranes.
- Brine Recovery System facilities to further concentrate the brine reject.

- Brine Recovery System facilities are energy/chemically intensive and they require membrane replacement every few years due to the brine reject water quality.
- An evaporation pond to handle the brine reject that has undergone further concentration by the Brine Recovery System.

The advanced treatment Tertiary UF/AOP/GAC/RO assumes that 100 percent of the flow is treated by the UF, AOP and GAC, and 50 percent of the flow is treated by the RO and then recombined with the remainder of GAC effluent. Sending a portion of flow through the RO and blending it with the balance of plant flows ensures a stable water to discharge to surface waters. The RO brine reject (about 1.0 mgd) undergoes BRS pre-treatment that further concentrates the brine reject to about 0.01 to 0.1 mgd. The recovery for both RO and BRS processes is highly dependent on water quality (e.g., silicate levels).

### Incremental Treatment Cost

The difference in costs between the baseline and the advanced treatment alternatives is listed in Table 4-8. The incremental cost to retrofit the baseline facility to the advanced treatment was calculated by taking the difference between the four alternatives. These values serve as a planning level benchmark for understanding the potential cost for retrofitting a particular facility. However, the actual incremental cost will be unique to a particular facility. Several reasons for the wide range in cost in retrofitting a baseline facility to advanced treatment are summarized as follows:

- Physical plant site constraints. A particular treatment technology may or may not fit within the constraints of a particular plant site. A more expensive technology solution that is more compact may be required. Alternately, land acquisition may be necessary to enlarge a plant site to allow for the addition of advanced treatment facilities. An example of the former is stacking treatment processes vertically to account for footprint space constraints. This is an additional financial burden that would not be captured in the incremental costs presented in Table 4-8. Yard piping. Site specific conditions may prevent the most efficient layout and piping arrangement for an individual facility. This could lead to additional piping and pumping to convey the wastewater through the plant. This is an additional financial burden that would not be captured in the incremental costs presented in Table 4-8.
- Pumping stations. Each facility has a unique hydraulic profile that might require additional pumping stations not captured in this planning level analysis. This is an additional financial burden that would not be captured in the incremental costs presented in Table 4-8.

An assessment was completed to compare costs for facilities with lower capacity (0.5 mgd) as presented in Table 4-8, as well as at a higher capacity (25 mgd) as presented in Table 4-9. It is well-documented that wastewater projects are impacted by economies of scale, whereby the unit costs (e.g., \$/gpd) typically decrease as facilities increase in size. To account for such, the capital costs were adjusted based on non-linear scaling equations with scaling exponents. The scaling exponent values were based on HDR



experience. In contrast, O&M costs were adjusted with linear scaling. These two scaled costs were combined to calculate total NPV costs and NPV unit costs.

The NPV unit cost for Baseline treatment for 0.5 mgd ranges between \$38 to \$93 per gallon per day, and the incremental cost between Baseline and Advanced Treatment ranges from \$31 to \$168 per gallon per day.

**Table 4-8. Treatment Technology Total Project Costs in 2022 Dollars for a 0.5 mgd Facility**

Alternative	Total Construction Cost (\$ Million)	O&M Net Present Value (\$ Million)	Total Net Present Value (\$ Million)	NPV Unit Cost (\$/gpd)
Baseline (Conventional Secondary Treatment)	18 - 45	1 - 2	19 - 29	38 - 93
Advanced Treatment – Tertiary UF/RO*				
Baseline (from the top of the table)	18 - 45	1 - 2	19 - 29	38 - 93
Additional Cost (beyond Baseline) for UF/RO	19 - 47	2 - 5	21 - 32	42 - 103
Total Cost (includes Baseline): Advanced Treatment - UF/RO*	37 - 91	3 - 7	40 - 61	80 - 197
Advanced Treatment – Tertiary UF/GAC				
Baseline (from the top of the table)	18 - 45	1 - 2	19 - 29	38 - 93
Additional Cost (beyond Baseline) for UF/GAC	13 - 32	2 - 5	15 - 24	31 - 75
Total Cost (includes Baseline): Advanced Treatment - UF/GAC	31 - 77	3 - 7	34 - 53	68 - 169
Advanced Treatment – Tertiary UF/AOP/GAC				
Baseline (from the top of the table)	18 - 45	1 - 2	19 - 29	38 - 93
Additional Cost (beyond Baseline) for UF/AOP/GAC	17 - 41	3 - 8	20 - 30	39 - 97
Total Cost (includes Baseline): Advanced Treatment - UF/AOP/GAC	35 - 86	4 - 10	39 - 59	77 - 190

Alternative	Total Construction Cost (\$ Million)	O&M Net Present Value (\$ Million)	Total Net Present Value (\$ Million)	NPV Unit Cost (\$/gpd)
Advanced Treatment – Tertiary UF/AOP/GAC/RO				
Baseline (from the top of the table)	18 - 45	1 - 2	19 - 29	38 - 93
Additional Cost (beyond Baseline) for UF/AOP/GAC/RO	29 - 73	5 - 12	34 - 53	68 - 168
Total Cost (includes Baseline): Advanced Treatment - UF/AOP/GAC/RO	48 - 117	5 - 13	53 - 82	106 - 262

\* Assumes Brine Recovery System for RO brine management, followed by evaporation ponds. Other options are available as listed in Section 4.3.2.

The NPV unit cost for Baseline treatment for 25 mgd ranges between \$9 to \$22 per gallon per day and the incremental cost between Baseline and Advanced Treatment ranges from \$18 to \$74 per gallon per day.

The larger 25 mgd plant is not as expensive on a unit cost basis (\$/gpd) of treatment capacity. This dissimilarity in the unit costs (\$/gpd) between the 0.5 and 25 mgd of treatment capacity is attributed to economies of scale. Cost curve comparisons (potential total construction cost and total net present value) for the baseline and the four tertiary treatment options (UF/RO, UF/GAC, UF/AOP/GAC and UF/AOP/GAC/RO) are shown in Figure 4-11 and Figure 4-12. It is important to note that while the economies of scale suggest lower incremental costs for the larger size facilities, some aspects of the advanced treatment processes may become infeasible at larger capacities due to factors such as physical space limitations and the large size requirements for components such as RO reject brine management.

**Table 4-9. Treatment Technology Total Project Costs in 2022 Dollars for a 25 mgd Facility**

Alternative	Total Construction Cost (\$ Million)	O&M Net Present Value (\$ Million)	Total Net Present Value (\$ Million)	NPV Unit Cost (\$/gpd)
Baseline (Conventional Secondary Treatment)	190 - 468	38 - 94	228 - 351	9 - 22
Advanced Treatment – Tertiary UF/RO*				
Baseline (from the top of the table)	190 - 468	38 - 94	228 - 351	9 - 22



Alternative	Total Construction Cost (\$ Million)	O&M Net Present Value (\$ Million)	Total Net Present Value (\$ Million)	NPV Unit Cost (\$/gpd)
Additional Cost (beyond Baseline) for UF/RO	370 - 910	142 - 349	512 - 787	20 - 50
Total Cost (includes Baseline): Advanced Treatment - UF/RO*	388 - 955	143 - 351	530 - 816	21 - 52
Advanced Treatment – Tertiary UF/GAC				
Baseline (from the top of the table)	190 - 468	38 - 94	228 - 351	9 - 22
Additional Cost (beyond Baseline) for UF/GAC	309 - 761	146 - 359	455 - 700	18 - 45
Total Cost (includes Baseline): Advanced Treatment - UF/GAC	327 - 805	147 - 361	474 - 729	19 - 47
Advanced Treatment – Tertiary UF/AOP/GAC				
Baseline (from the top of the table)	190 - 468	38 - 94	228 - 351	9 - 22
Additional Cost (beyond Baseline) for UF/AOP/GAC	345 - 849	192 - 473	537 - 827	21 - 53
Total Cost (includes Baseline): Advanced Treatment - UF/AOP/GAC	363 - 894	193 - 475	556 - 856	22 - 55
Advanced Treatment – Tertiary UF/AOP/GAC/RO				
Baseline (from the top of the table)	190 - 468	38 - 94	228 - 351	9 - 22
Additional Cost (beyond Baseline) for UF/AOP/GAC/RO	480 – 1,182	273 - 672	753 – 1,159	30 - 74
Total Cost (includes Baseline): Advanced Treatment - UF/AOP/GAC/RO	498 – 1,226	274 - 674	772 – 1,188	31 - 76

\* Assumes Brine Recovery System for RO brine management, followed by evaporation ponds. Other options are available as listed in Section 4.3.2.

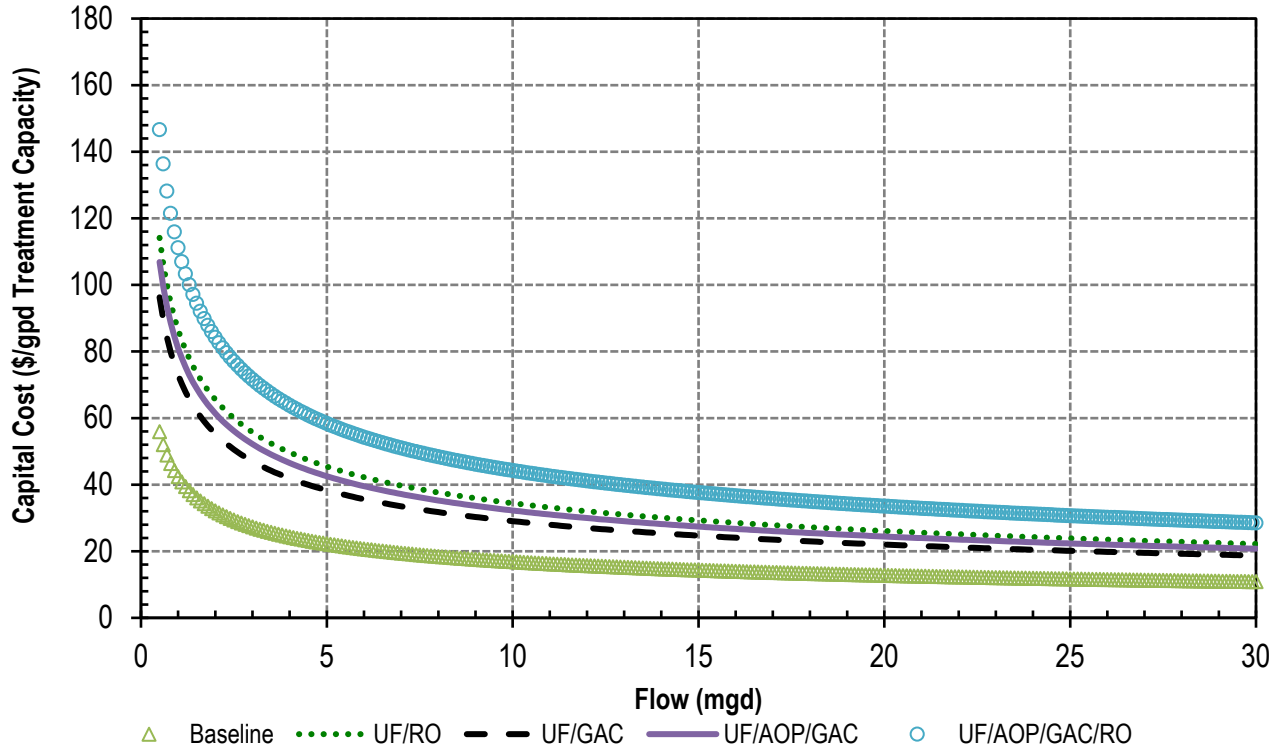

Figure 4-11. Capital Cost Curve Comparison for Baseline Treatment, UF/RO, UF/GAC, UF/AOP/GAC, and UF/AOP/GAC/RO

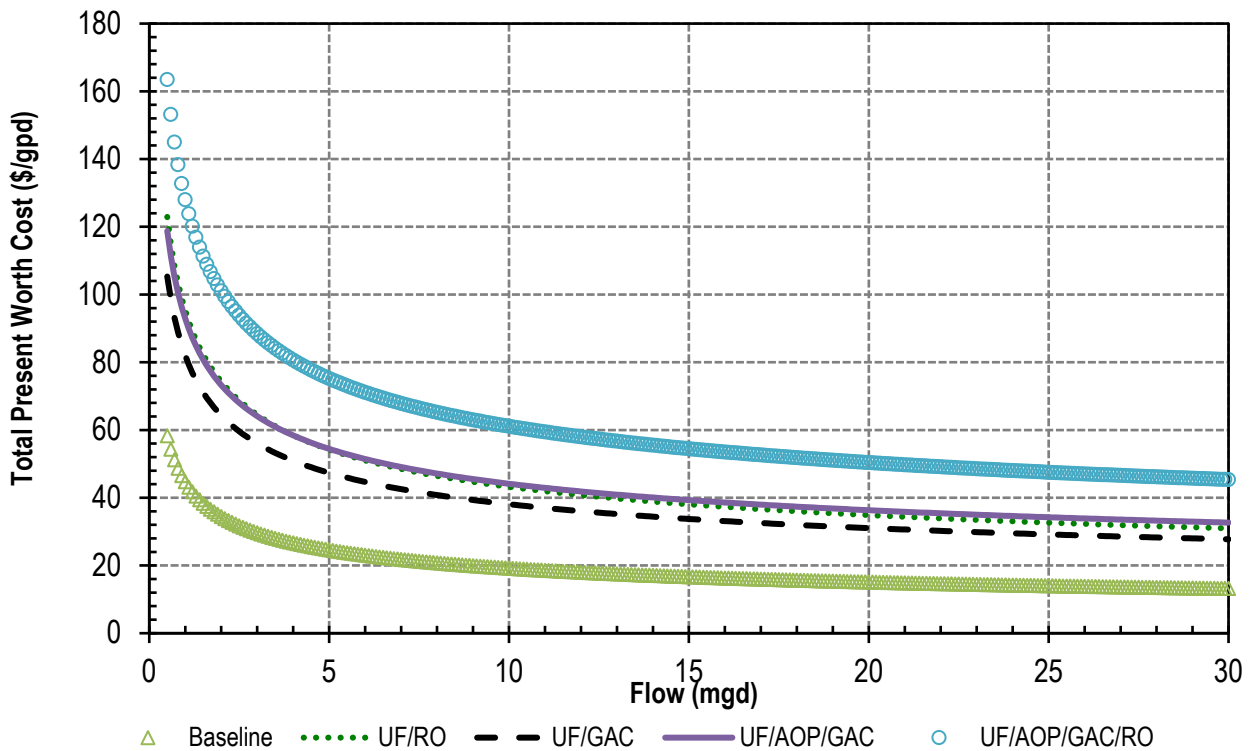

Figure 4-12. NPV Cost Curve Comparison for Baseline Treatment, UF/RO, UF/GAC, UF/AOP/GAC, and UF/AOP/GAC/RO

## 4.7 Pollutant Mass Removal

An estimate of the projected mass load reduction for the four constituents of concern was developed and is presented in Table 4-10. The current secondary effluent and advanced treatment effluent data is based on the information available from municipal treatment plant facilities. Effluent data is limited for advanced treatment facilities such as UF/RO, UF/GAC, UF/AOP/GAC and UF/AOP/GAC/RO at concentrations as low as the human health water quality criteria for Washington. Due to this lack of effluent performance data, advanced treatment was assumed to remove an additional 50 to 95 percent of the constituents, resulting in the range of potential effluent concentration values presented in Table 4-10. It is important to note that these estimates are based on limited data and are presented here simply for the purpose of quantifying potential mass removals. Current secondary effluent for industrial facilities would likely be greater than the data presented here for municipal wastewater facilities. As a result, the projected effluent concentrations and loads for industrial facilities would likely be higher.

**Table 4-10. Pollutant Mass Removal by Contaminant for a 5 mgd Facility**

Component	Arsenic	BAP	Mercury	PCBs
Required HHWQC based Effluent Quality (µg/L)	0.018	0.000016	0.0005	0.000007
Current Secondary Effluent Concentration (µg/L)*	5	0.006	0.025	0.002
Projected Effluent Quality (µg/L) from Advanced Treatment*	0.25 - 2.5	0.0003 - 0.003	0.00125 - 0.0125	0.0001 - 0.001
Mass Removed (mg/d)**	47,300 – 89,930	57 – 108	240 - 450	19 – 36
Mass Removed (lb/d)**	0.104-0.198	0.00013 – 0.00024	0.00052 – 0.00099	0.00004 – 0.00008

\* Estimated at 50-95 percent removal of Current Secondary Effluent Concentration.

\*\* 1 lb = 454,000 mg

HHWQC=human health-based water quality criteria

MF/RO=membrane filtration/reverse osmosis

MF/GAC=membrane filtration/granulated activated carbon

µg/L=micrograms per liter

mg/d=milligrams per day

lb/d=pounds per day

Unit costs were developed based on required mass removal from a 5 mgd facility for each of the four constituents of concern to reduce discharges from current secondary effluent quality to the assumed required effluent quality (HHWQC). It is important to note that this study concludes it is unclear if existing technology can meet the required effluent quality, however, the information presented in Table 4-11 assumes HHWQC would be met for developing unit costs and uses the costs for UF/RO as an example. The unit

costs are expressed as dollars in NPV (over a 20-year period) per pound of constituent removed over the same 20-year period as seen in the equation below:

*(Current Secondary Effluent Concentration – Required HHWQC based Effluent Quality)*

$$* 8.34 * 5 \text{ mgd} * 365 \text{ days} * 20 \text{ years}$$

The current secondary effluent quality data presented are based on typical secondary effluent quality expected for a municipal/industrial discharger. Table 4-11 suggests unit costs are most significant in meeting the PCB, BAP, and mercury required effluent quality.

**Table 4-11. Unit Cost by Contaminant for a 5 mgd Facility Implementing Advanced Treatment using UF/RO**

Component	Arsenic	BAPs	Mercury	PCBs
Required HHWQC based Effluent Quality (µg/L)	0.018	0.000016	0.0005	0.000007
Current Secondary Effluent Concentration (µg/L)*	5	0.006	0.025	0.002
Total Mass Removed (lb) over 20-year Period**	1,517	1.82	7.5	0.61
Unit Cost (NPV \$/lb removed over 20-years)**	\$201,000	\$170,000,000	\$41,000,000	\$500,000,000

\* Derived from data presented in Table 4-10.

\*\* 20-year NPV of \$305,000,000, the average of the range presented in Table 4-7 for advanced treatment using UF/RO.

NPV=net present value

HHWQC=human health-based water quality criteria

µg/l=micrograms per liter

## 4.8 Sensitivity Analysis

The ability of dischargers to meet a HHWQC one order of magnitude less stringent than the HHWQC presented in Table 2-1 was considered. The same advanced treatment technologies using UF/RO, UF/GAC, UF/AOP/GAC, or UF/AOP/GAC/RO would be applied to meet revised effluent quality one order-of-magnitude less stringent. Based on available data for estimated effluent quality, it appears the arsenic and mercury limits may be met at a less stringent HHWQC, depending upon how effluent limits were structured in discharge permits. Compliance may be feasible with effluent limits based on long term average mass loadings, while successful compliance with maximum day concentration limits is unlikely. Compliance with one order-of-magnitude less stringent BAP and PCB concentration limits would still be unlikely. It is important to note that a discharger's ability to meet these less stringent limits depends on existing secondary effluent characteristics and is facility specific. Facilities with higher secondary effluent constituent concentrations will have greater difficulty meeting HHWQC.



## 5 Summary and Conclusions

This study evaluated treatment technologies potentially capable of meeting revised effluent discharge limits associated with revised HHWQC. A literature review of potential technologies was conducted to evaluate and screen treatment methods for meeting revised effluent limits for four constituents of concern: arsenic, BAP, mercury, and PCBs. Four alternatives were selected to compare against a secondary treatment baseline, including enhanced secondary treatment with UF/RO, UF/GAC, UF/AOP/GAC, or UF/AOP/GAC/RO. Capital and operating costs were estimated, and a net present value (NPV) was calculated for each alternative, including the incremental cost to add advanced treatment to an existing secondary treatment facility.

The following conclusions can be made from this study.

- Revised HHWQC based on EPA's proposed Human Health Criteria for Washington (Federal Register 2022) will result in very low water quality criteria for toxic constituents.
- There are limited "proven" technologies available for dischargers to meet all required effluent quality limits that would be derived from revised HHWQC.
- Current secondary wastewater treatment facilities provide high degrees of removal for toxic constituents; however, they will not be capable of compliance with all water quality-based NPDES permit effluent limits derived from EPA's proposed HHWQC for Washington.
- Advanced treatment technologies have been investigated and candidate process trains have been conceptualized for toxics removal.
- Advanced wastewater treatment technologies may enhance toxics removal rates; however, they will not be capable of compliance with HHWQC based effluent limit for PCBs. The lowest levels achieved based on the literature review were between  $<0.00001$  and  $0.0002 \mu\text{g/L}$ , two orders-of-magnitude greater than the proposed HHWQC of  $0.000007 \mu\text{g/L}$ .
- Compliance with a HHWQC for arsenic of  $0.018 \mu\text{g/L}$  is questionable, even for the most elaborate treatment process trains, because little performance data is available from facilities operating at these low concentrations. Most treatment technology performance information available in the literature is based on drinking water treatment applications targeting a much higher Safe Drinking Water Act (SDWA) Maximum Contaminant Level (MCL) of  $10 \mu\text{g/L}$ . Data from a confidential demonstration project using UF/RO/AOP shows performance to the same order-of-magnitude at  $<0.036 \mu\text{g/L}$  versus the proposed HHWQC  $0.018 \mu\text{g/L}$ . It is possible this demonstration project is producing effluent near proposed HHWQC for arsenic.
- Compliance with EPA's proposed methylmercury tissue concentration criteria of  $0.03 \text{ mg/kg}$  appears unlikely. The range of potential water column concentrations for methylmercury associated with EPA's proposed  $0.03 \text{ mg/kg}$  tissue

concentration are lower than the approved analytical methods in 40 CFR part 136 for Method 1631E with a quantitation level of 0.0005 µg/L. Consequently, treatment facilities would need to target non-detectable levels of effluent methylmercury less than 0.0005 µg/L.

- Little information is available to assess the potential for advanced technologies to comply with revised BAP criteria, but compliance appears unlikely. A municipal wastewater treatment plant study reported both influent and effluent BAP concentrations of <0.0057 µg/L, two orders-of-magnitude greater than the proposed HHWQC of 0.000016 µg/L (Ecology, 2010).
  - Some technologies may be effective at treating identified constituents of concern to meet revised limits while others may not. It is therefore even more challenging to identify a technology that can meet all constituent limits simultaneously. Multiple technologies paired together may be necessary.
  - A HHWQC that is one order-of-magnitude less stringent might be satisfied for arsenic and mercury, however compliance with less-stringent BAP and PCB limits would still be unlikely.
- Advanced treatment processes incur significant capital and operating costs.
  - Advanced treatment processes to remove additional arsenic, BAP, mercury, and PCBs would combine enhancements to secondary treatment with ultrafiltration membranes, an advanced oxidation process, reverse osmosis or granular activated carbon and increase the estimated capital cost of treatment from \$16 to \$39 to up to \$31 to \$120 \$/gpd of treatment capacity (based on a 5.0-million-gallon-per-day (mgd) facility).
  - The operation and maintenance NPV costs for the advanced treatment process train will be substantially higher, between \$29 and \$135 million versus \$8 to \$19 million, over 20 years.
- Implementation of additional treatment will result in additional collateral impacts including:
  - High energy consumption.
  - Increased greenhouse gas emissions.
  - Increase in solids production from chemical addition to the primaries. Additionally, the membrane and GAC facilities will capture more solids that require processing and utilization or disposal.
  - Increased physical space requirements at treatment plant sites for advanced treatment facilities and residuals management, including reverse osmosis reject brine processing.
- It appears advanced treatment technology alone would not be capable of compliance with potential water quality based effluent limits resulting from the proposed HHWQC and that alternative compliance tools, such as variances, would be necessary for discharger compliance.



- Implementation flexibility will be necessary to reconcile the difference between the capabilities of treatment processes and the potential for HHWQC driven water quality based effluent limits to be lower than attainable with current technology.

## 6 References

- Andrianisa, H.,A., Ito, A., Sasaki, A., Aizawa, J., and Umita, T. 2008. Biotransformation of arsenic species by activated sludge and removal of bio-oxidised arsenate from wastewater by coagulation with ferric chloride. *Water Research*, 42(19): 4809-4817
- Andrianisa, H.,A., Ito, A., Sasaki, A., Ikeda, M., Aizawa, J., and Umita, T. 2006. Behaviour of arsenic species in batch activated sludge process: biotransformation and removal. *Water Science and Technology*, 54(8): 121-128.
- Bolzonella, D.; Fatone, F.; Pavan, P.; Cecchi, F. 2010. Poly-chlorinated dibenzo-p-dioxins, dibenzo-furans and dioxin-like poly-chlorinated biphenyls occurrence and removal in conventional and membrane activated sludge processes. *Bioresource Technology*, 101(24): 9445-9454.
- Bare, J., G. Norris, D. Pennington, and T. McKone. 2003. TRACI: The tool for the reduction and assessment of chemical and other environmental impacts. *Journal of Industrial Ecology*, 6(3-4): 49-78.
- Bare, J. 2011. TRACI 2.0: the tool for the reduction and assessment of chemical and other environmental impacts 2.0. *Clean Technology and Environmental Policy*. 13(5): 687-696.
- Bhattacharyya, D.; Barranger, T.; Jevtitch, M.; and Greenleaf, S. 1987. Separation of Dilute Hazardous Organics by Low Pressure Composite Membranes. EPA Report, EPA/600/87/053.
- Bolzonella, David, Fatone, F., Pavan, P., and Cecchi, F. (2010). Poly-chlorinated dibenzo-p-dioxins, dibenzo-furans and dioxin-like poly-chlorinated biphenyls occurrence and removal in conventional and membrane activated sludge processes
- Brown, M., and Lester, J. (1979). Metal removal in activated sludge: The role of bacterial extracellular polymers. *Water Research*, 13(9), 817–837. [https://doi.org/10.1016/0043-1354\(79\)90217-3](https://doi.org/10.1016/0043-1354(79)90217-3)
- Burbano, A and Brandhuber, P. (2012) Demonstration of membrane zero liquid discharge for drinking water systems. Water Environment Research Federation (WERF) Report WERF5T10.
- California Air Resources Board, ICLEI, California Climate Action Registry, The Climate Registry. 2008. Local Government Operations Protocol. For the quantification and reporting of greenhouse gas emissions inventories, Version 1.1.
- CFR 2022a. Code of Federal Regulations. Title 40 Chapter 1 Subchapter D Part 131. Water Quality Standards. 131.45 Revisions of certain Federal water quality criteria applicable to Washington. [eCFR :: 40 CFR Part 131 -- Water Quality Standards](#) Accessed March 2022.
- CFR 2022b. Code of Federal Regulations Title 40 Chapter 1 Subchapter D Part 136. [eCFR 40 CFR Part 136 -- Guidelines Establishing Test Procedures for the Analysis of Pollutants](#) Accessed March 2022.
- Chang, J.; Peng, D.; Deng, S.; Chen, J.; Duan, C. 2022. Efficient treatment of mercury(II)-containing wastewater in aerated constructed wetland microcosms packed with biochar. *Chemosphere*, 290.
- Chung, B., Cho, J., Song, C., and Park, B. Degradation of naturally contaminated polycyclic aromatic hydrocarbons in municipal sewage sludge by electron beam irradiation. *Bulletin of Environmental Contamination and Toxicology*, 81(1): 7-11.
- City of Coeur d'Alene. 2021. PCB and TCDD Toxics Management Plan Annual Report.

- City of Winnipeg. 2012. Emission Factors in kg CO<sub>2</sub>-Equivalent per Unit. Available online: [http://www.winnipeg.ca/finance/findata/matmgt/documents/2012/682-2012/682-2012\\_Appendix\\_H-WSTP\\_South\\_End\\_Plant\\_Process\\_Selection\\_Report/Appendix%207.pdf](http://www.winnipeg.ca/finance/findata/matmgt/documents/2012/682-2012/682-2012_Appendix_H-WSTP_South_End_Plant_Process_Selection_Report/Appendix%207.pdf)
- CRITFC (Columbia River Inter-Tribal Fish Commission). 1994. A fish consumption survey of the Umatilla, Nez Perce, Yakama and Warm Springs Tribes of the Columbia River Basin. Columbia River Inter-Tribal Fish Commission Report reference #94-03, Portland, Oregon.
- Eckenfelder, W.W., Industrial Water Pollution Control, 2nd ed. (New York: McGraw-Hill, 1989).
- Ecology. 2010. (Lubliner, B., M. Redding, and D. Ragsdale). Pharmaceuticals and Personal Care Products in Municipal Wastewater and Their Removal by Nutrient Treatment Technologies. Washington State Department of Ecology, Olympia, WA. Publication Number 10-03-004.
- Ecology 2016. Washington State Water Quality Standards: Human Health Criteria and Implementation Tools, Overview of Key Decisions in Rule Amendment. Washington State Department of Ecology. Water Quality Program. Olympia, WA. Publication No. 16-10-025.
- Ecology. Draft 2020. Preliminary Draft State Technical Support Document for PCB Variances on the Spokane River. Chapter 173-201A WAC, Water Quality Standards for Surface Waters of the State of Washington. Washington State Department of Ecology, Olympia, WA.
- Energy Star and U.S. Environmental Protection Agency (EPA) (2021) Energy Star Portfolio Manager: U.S. Energy Use Intensity by Property Type. Technical Reference. Washington, D.C.
- Falk, M., Neethling, J.B., and Reardon, D.J. (2011). "Striking the Balance between Nutrient Removal in Wastewater Treatment and Sustainability." WRF Nutrient Removal Challenge Report NUTR1R06n.
- Federal Register. 2022. Environmental Protection Agency. 40 CFR Parts 131. Restoring Protective Human Health Criteria in Washington. EPA-HQ-OW-2015-0174; FRL-7253.1-01-OW. 19046 - 19063.
- Ge, J.; Guha, B.; Lippincott, L.; Cach, S.; Wei, J.; Su, T.-L.; Meng, X. 2020. Challenges of arsenic removal from municipal wastewater by coagulation with ferric chloride and alum. *Science of The Total Environment*, 725.
- Ghosh, U.; Weber, A.S.; Jensen, J.N.; Smith, J.R. 1999. Granular Activated Carbon and Biological Activated Carbon Treatment of Dissolved and Sorbed Polychlorinated Biphenyls. *Water Environment Research*, 71: 232-240.
- González, D., Ruiz, L.M., Garralón, G., Plaza, F., Arévalo, J., Parada, J., Pérez, J., Morena, B., and Ángel Gómez, M. 2012. Wastewater polycyclic aromatic hydrocarbons removal by membrane bioreactor. *Desalination and Water Treatment*, 42: 94–99
- Gupta, H. and Gupta, B. (2016) Adsorption of polycyclic aromatic hydrocarbons on banana peel activated carbon. *Desalination and Water Treatment*, 57(20): 9498-9509
- Grosser, J. 2010. The Challenge: Measure Arsenic in Drinking Water. White paper.
- Haapeaa, P., and Tuhkanen, T. 2006. Integrated treatment of PAH contaminated soil by soil washing, ozonation and biological treatment. *Journal of Hazardous Materials*, 136(21): 244-250

- HDR. 2013. Treatment Technology Review and Assessment. Association of Washington Business, Association of Washington Cities, and Washington State Association of Counties.
- Hua, K.; Xu, X.; Luo, Z.; Fang, D.; Bao, R.; Yi, J. 2020. Effective Removal of Mercury Ions in Aqueous Solutions: A Review. *Current Nanoscience*, 16(3): 363-375.
- Hollerman, W. (1999). Results from the low Level Mercury Sorbent Test at the Oak Ridge Y-12 plant in Tennessee. *Journal of Hazardous Materials*, 68(3), 193–203. [https://doi.org/10.1016/s0304-3894\(99\)00027-8](https://doi.org/10.1016/s0304-3894(99)00027-8)
- Intergovernmental Panel on Climate Change. 2006. 2006 IPCC Guidelines for National Greenhouse Gas Inventories. Prepared by the National Greenhouse Gas Inventories Programme, Eggleston, S., Buendia, L., Miwa, K., Ngara, T., Tanabe, K. (eds.) Published: IGES, Japan.
- Intergovernmental Panel on Climate Change. 2013. The Physical Science Basis. Contribution of Working Group I to the Fifth Assessment Report of the Intergovernmental Panel on Climate Change. Cambridge University Press, USA (2013)
- LaGrega, M.D., Buckingham P.L. and Evans J.C., Hazardous Waste Management, 1st ed. (New York: McGraw-Hill, 1994).
- Ledakowicz, S., Miller, J. S., & Olejnik, D. (1999). Oxidation of PAHs in water solutions by ultraviolet radiation combined with hydrogen peroxide. *International Journal of Photoenergy*, 1(1), 55–60.
- Light, W. 1981. "Removal of Chemical Carcinogens from Water/Wastewater by Reverse Osmosis". Chemistry in Water Reuse, Vol. 1, W.J. Cooper, ed., Ann Arbor Science, Ann Arbor, Michigan.
- Melcer, H., Steel, P., and Bedford, W.K. 1993. Removal of polycyclic aromatic hydrocarbons and heterocyclic nitrogenous compounds by a POTW receiving industrial discharges. Proceeding of WEFTEC 1993.
- Mickley and Associates. 2006. Membrane Concentrate Disposal: Practices and Regulations. U.S. Department of the Interior, Bureau of Reclamation, Contract No. 98-FC-81-0054.
- Mojiri, A.; Zhou, J.L.; Ohashi, A.; Ozaki, N.; Kindaichi, T. 2019. Comprehensive review of polycyclic aromatic hydrocarbons in water sources, their effects and treatments. *Science of The Total Environment*, 696.
- National Council for Air and Stream Improvement, Inc. (NCASI). 1998. Technical and economic feasibility assessment of metals reduction in pulp and paper mill wastewaters. Technical Bulletin No. 756. Research Triangle Park, NC: National Council for Air and Stream Improvement, Inc.
- National Council for Air and Stream Improvement, Inc. (NCASI). 2004. Investigation of advanced techniques to remove low-level mercury from pulp and paper mill effluents. Technical Bulletin No. 870. Research Triangle Park, NC: National Council for Air and Stream Improvement, Inc.
- National Council for Air and Stream Improvement, Inc. (NCASI). 2000. Memorandum: Information on PCB Water Quality Criteria, Analytical Methods, and Measurement Results for Point Sources and Ambient Waters. Technical Bulletin No. 807. Research Triangle Park, NC: National Council for Air and Stream Improvement, Inc.

- National Council for Air and Stream Improvement, Inc. (NCASI). 2000. Bench scale testing of processes to reduce metals concentrations in pulp and paper mill wastewaters. Technical Bulletin No. 807. Research Triangle Park, NC: National Council for Air and Stream Improvement, Inc.
- National Council for Air and Stream Improvement, Inc. (NCASI). 2022. Paul Wiegand, NACASI Vice President of Water Resources and Laboratory Operations, Personal Communication with Ken Johnson. January 11, 2022.
- Ning, R. 2002. Arsenic removal by reverse osmosis. *Desalination*, 143(3): 237-241.
- Oleszczuk, P., Hale, S. E., Lehmann, J., and Cornelissen, G. 2012. Activated carbon and biochar amendments decrease pore-water concentrations of polycyclic aromatic hydrocarbons (PAHs) in sewage sludge. *Bioresource Technology*, 111: 84–91.
- Oleszczuk, P; Zielińska, A.; Cornelissen, G. 2014. Stabilization of sewage sludge by different biochars towards reducing freely dissolved polycyclic aromatic hydrocarbons (PAHs) content. *Bioresource Technology*, 156: 139-145.
- Olujimi, O. O., Fatoki, O. S., Odendaal, J., Daso, A. P., & Oputu, O. (2012). Preliminary Investigation into Occurrence and Removal of Arsenic, Cadmium, Mercury, and Zinc in Wastewater Treatment Plants in Cape Town and Stellenbosch. *Polish Journal of Environmental Studies*, 1755–1765.
- Oregon Department of Environmental Quality. 2011. Table 40: Human Health Water Quality Criteria for Toxic Pollutants, Effective October 17, 2011. Available on-line at: <http://www.deq.state.or.us/wq/standards/toxics.htm>
- Owen, W.F. 1982. *Energy in Wastewater Treatment*. Prentice-Hall, Englewood Cliffs, New Jersey.
- Parker, W., Monteith, H., and Pileggi, V. 2009. Estimation of Biodegradation and Liquid-Solid Partitioning Coefficients for Complex PAHs in Wastewater Treatment. *Proceedings of the Water Environment Federation 2009*: 2537-2554.
- Peng, L.; Dai, X.; Liu, Y.; Jing Sun, W.W.; Xie, G.-J.; Wang, D.; Song, S.; Ni, B.-J. 2018. Kinetic assessment of simultaneous removal of arsenite, chlorate and nitrate under autotrophic and mixotrophic conditions. *Science of The Total Environment*, 628–629: 85-93.
- Pettine, M., Campanella, L., & Millero, F. J. (1999). Arsenite oxidation by H<sub>2</sub>O<sub>2</sub> in aqueous solutions. *Geochimica Et Cosmochimica Acta*, 63(18), 2727–2735. [https://doi.org/10.1016/s0016-7037\(99\)00212-4](https://doi.org/10.1016/s0016-7037(99)00212-4)
- Rodenburg. L.A.; Hermanson, M.R.; Sumner, A.L. 2022. Effect of membrane filtration on the fate of polychlorinated biphenyls in wastewater treatment. *Chemosphere*, 287, Part 3.
- Rodrigue, P., and Rielly, A. 2009. Effectiveness of a membrane bioreactor on weak domestic wastewater containing polychlorinated biphenyls. *Proceedings of the Water Environment Federation, Microconstituents and Industrial Water Quality 2009*, 11: 174-184.
- Russo, L., Rizzo, L., and Belgiorno, V. 2012. Ozone oxidation and aerobic biodegradation with spent mushroom compost for detoxification and benzo(a)pyrene removal from contaminated soil. *Chemosphere*, 87(6): 595-601
- SimaPro 6. 2008. *Life Cycle Analysis Software*. The Netherlands.

- Smol M.; Włodarczyk-Makuła, M. 2017. Effectiveness in the Removal of Organic Compounds from Municipal Landfill Leachate in Integrated Membrane Systems: Coagulation – NF/RO. *Polycyclic Aromatic Compounds*, 37(5): 456-474
- Sponza, D., and Oztekin, R. 2010. Effect of sonication assisted by titanium dioxide and ferrous ions on polyaromatic hydrocarbons (PAHs) and toxicity removals from a petrochemical industry wastewater in Turkey. *Journal of Chemical Technology & Biotechnology*, 85(7): 913-925.
- Urgun-Demirtas, Meltam, Benda, P., Gillenwater, P., Negri, M.C., Xiong, H., and Snyder, S.W. 2012. Achieving very low mercury levels in refinery wastewater by membrane filtration. *Journal of Hazardous Materials*, 215–216: 98-107.
- U.S. Department of Agriculture (USDA). 1998. Continuing survey of food intakes by individuals: 1994-96, 1998. U.S. Department of Agriculture, Agricultural Research Service.
- U.S. Environmental Protection Agency (EPA). 2000. Methodology for Deriving Ambient Water Quality Criteria for the Protection of Human Health. EPA- 822-B-00-004, October 2000.
- U.S. Environmental Protection Agency (EPA). 2003. Arsenic Treatment Technology Handbook for Small Systems, EPA 816R03014.
- U.S. Environmental Protection Agency (EPA). 2007a. "Treatment Technologies for Mercury in Soil, Waste, and Water". Washington, DC: Office of Superfund Remediation and Technology Innovation. Available from EPA's web site: [https://www.epa.gov/sites/default/files/2015-08/documents/treat\\_tech\\_mercury\\_542r07003.pdf](https://www.epa.gov/sites/default/files/2015-08/documents/treat_tech_mercury_542r07003.pdf)
- U.S. Environmental Protection Agency (EPA). 2007b. Analytical Methods for Mercury in National Pollutant Discharge Elimination System (NPDES) Permits. James A. Hanlon, Director, Office of Wastewater Management. Water Division Directors, Regions 1-10. August 23, 2007.
- U.S. Environmental Protection Agency (EPA). 2010a. Guidance for Implementing the January 2001 Methylmercury Water Quality Criterion. EPA-823-R-10-001. Office of Science and Technology. Washington, DC.
- U.S. Environmental Protection Agency (EPA). 2010b. Method 1668C Chlorinated Biphenyl Congeners in Water, Soil, Sediment, Biosolids, and Tissue by HRGC/HRMS April 2020 [Method 1668C: Chlorinated Biphenyl Congeners in Water, Soil, Sediment, Biosolids, and Tissue by HRGC/HRMS \(epa.gov\)](#) Accessed March 2022.
- U.S. Environmental Protection Agency (EPA). 2013. NPDES Permit, City of Coeur d'Alene Wastewater Facility (ID0022853).
- U.S. Environmental Protection Agency (EPA). 2014. "Emission Factors for Greenhouse Gas Inventories" Washington, DC: Office of Atmospheric Programs, Clean Air Markets Division. Available from EPA's eGRID web site: <https://www.epa.gov/eGRID>
- U.S. Environmental Protection Agency (EPA). 2015. Federal Register. Revision of Certain Federal Water Quality Criteria Applicable to Washington. A Proposed Rule by the Environmental Protection Agency on 09/14/2015.
- U.S. Environmental Protection Agency (EPA). 2016. Clean Water Act Effective Human Health Criteria Applicable to Washington. [CWA-Effective Human Health Criteria Applicable to Washington \(epa.gov\)](#) Accessed March 2022.
- U.S. Environmental Protection Agency (EPA). 2021. "Life Cycle and Cost Assessments of Nutrient Removal Technologies in Wastewater Treatment Plants". Prepared by Eastern Research



- Group, Inc. Washington, DC: Office of Water, Office of Science and Technology. Available from EPA's web site: <https://www.epa.gov/system/files/documents/2021-08/life-cycle-nutrient-removal.pdf>.
- U.S. Environmental Protection Agency (EPA). 2022. "Emissions & Generation Resource Integrated Database (eGRID), 2020" Washington, DC: Office of Atmospheric Programs, Clean Air Markets Division. Available from EPA's eGRID web site: <https://www.epa.gov/egrid>.
- U.S. Environmental Protection Agency (EPA). 2022a. Water Quality Standards for Surface Waters of the State of Washington. January 4, 2022. [Water Quality Standards for Surface Waters of the State of Washington \(epa.gov\)](#) Accessed March 2022.
- U.S. Environmental Protection Agency (EPA). 2022b. PCB Congeners by Low-Resolution GC-MS-Method 1628 (Not Yet Approved). Clean Water Act Analytical Methods. [PCB Congeners by Low-Resolution GC-MS - Method 1628 \(Not yet approved\) | US EPA](#) Accessed March 2022.
- Valkova, T.; Parravicinia, V.; Saracevic, E.; Tauber, J.; Svardal, K.; Krampe, J. (2021). A method to estimate the direct nitrous oxide emissions of municipal wastewater treatment plants based on the degree of nitrogen removal. *Journal of Environmental Management*, 279: 1-10.
- Verma, B.; Chandrajit, B. 2019. Surface modification of one-dimensional Carbon Nanotubes: A review for the management of heavy metals in wastewater. *Environmental Technology & Innovation*, 17.
- Wang, L.; Liu, X.; Lee, D.-J.; Tay, J.-H.; Zhang, Y.; Wan, C.-L.; Chen, X.-F. (2018) Recent advances on biosorption by aerobic granular sludge. *Journal of Hazardous Materials*, 357: 253-270.
- Water Environment Federation. 2009. Design of Municipal Wastewater Treatment Plants, WEF Manual of Practice 8, Fourth Edition, ASCE Manuals and Reports on Engineering Practice No. 76, Volume 1. Alexandria, VA.
- Water Environment Research Foundation (WERF). 2012. Demonstration of Membrane Zero Liquid Discharge for Drinking Water Systems, A Literature Review. WERF5T10.
- Water Environment Research Foundation (WERF). 2011. Striking the Balance Between Nutrient Removal in Wastewater Treatment and Sustainability. NUTR1R06n.
- WesTech brochure. Victorville case study. Vendor Brochure.
- Williams, M. 2003. A Review of Wastewater Treatment by Reverse Osmosis. White paper
- Worou, C.N.; Chen, Z.-L.; Bacharou, T. 2021. Arsenic removal from water by nanofiltration membrane: potentials and limitations. *Water Practice & Technology*, 16(2): 291-319.
- Yerushalmi, L., Nefil, S., Hausler, R., and Guiot, S. 2006. Removal of pyrene and benzo(a)pyrene from contaminated water by sequential and simultaneous ozonation and biotreatment. *Water Environment Research*, 78(11): 2286-2292.
- Yu, D.N.; Macawile, M.C.A.; Abella, L.C.; Gallardo, S.M. 2011. Degradation of polychlorinated biphenyls in aqueous solutions after UV-peroxide treatment: Focus on toxicity of effluent to primary producers. *Ecotoxicology and Environmental Safety*, 74(6): 1607-1614.
- Zeng, Y., Hong, A., and Wavrek, D. 2000. Integrated chemical-biological treatment of benzo[a]pyrene. *Environmental Science and Technology*, 34(5): 854-862.

*This page is intentionally left blank.*



## 7 Appendices

Appendix A - Unit Process Sizing Criteria

Appendix B - Greenhouse Gas Emissions Calculation Assumptions

*This page is intentionally left blank.*



## Appendix A. Unit Process Sizing Criteria

**Table A-1. Unit Processes Sizing Criteria for Each Alternative**

Unit Process	Units	Baseline Treatment	Advanced Treatment	Comment
Influent Pumping Station	mgd	15	15	Sized for Peak Hour Flow
Screening	mgd	15	15	Sized for Peak Hour Flow
Grit	mgd	15	15	Sized for Peak Hour Flow
Ferric Dose for CEPT (optional)	mg/L	20	20	This is the metal salt upstream of the primaries
Primary Clarifiers	gpd/sf	1,000/2000	1,000/2000	1,000 is for Average Annual; 2,000 is for Peak Hour. Peak Hour controls for the flows in this report
Primary Solids Pumping Station	mgd	6.25	6.25	Sized for the solids produced from clarifiers at an influent Maximum Month Flow (6.25 mgd)
Aeration System Oxygen Uptake Rate (OUR)	mg/L/hr	30	30	Average annual OUR is used in tandem with mixed liquor to determine the required aeration basin volume (the limiting parameter governs the activated sludge basin volume)
Aeration Basin Mixed Liquor	mg/L	1,250	2,500	Average annual mixed liquor is used in tandem with OUR (see previous row) to determine the required aeration basin volume (the limiting parameter governs the activated sludge basin volume)
Secondary Clarifiers Hydraulic Loading	gpd/sf	1200	1200	Applied to Peak Hour Flow, as clarifiers governed by hydraulic loading rate
Return Activated Sludge (RAS) Pumping Station	mgd	6.25	6.25	RAS must have capacity to meet 100% influent Max Month Flow
Waste Activated Sludge (WAS) Pumping Station	mgd	6.25	6.25	Sized for the solids produced from clarifiers at the Maximum Month Flow (6.25 mgd)
Flow Equalization Tank	mgd	--	6.25	EQ tank sized to trim any flow between Max Month Flow (6.25 mgd) and Peak hour flow (15 mgd) down to Max month flow
Alum Addition pre UF	mg/L	--	20	at Average Annual Flow
Ultrafiltration (UF) Flux	gallon per square foot per day (gfd)	--	25	At Average annual Flow
Pre-RO Chlorine Feed	mg/L	--	1	At Maximum Month Flow



Unit Process	Units	Baseline Treatment	Advanced Treatment	Comment
Reverse Osmosis (RO)	gallon per square foot per day (gfd)	--	10	At Average Annual Flow
RO Reject	%	--	20	This represents the percentage of feed flow that is rejected as brine and used to size the Brine Recovery System
GAC Pump Station	mgd	--	6.25	Sized for Maximum Month Flow
GAC Pressure Filters	Empty Bed Contact Time (minutes)	--	25	
GAC Pressure Filters	mgd	--	6.25	Sized for Maximum Month Flow
GAC Spent Media Storage	MG	--	Volume of Filters	Equal to the volume of all filters
GAC Virgin Media Storage	MG	--	Volume of Filters	Equal to the volume of all filters
Chlorination Dose	mg/L	10	10	At Peak Hour Flow (15 mgd)
Chlorination Storage Capacity	days	14	14	At Average Annual Conditions
Chlorine Contact Tank	min	15	15	This is for Peak Hour conditions.
Dechlorination Dose	mg/L	10	10	At Peak Hour Flow (15 mgd)
Dechlorination Storage Capacity	days	14	14	At Average Annual Conditions
Gravity Thickener	mgd	6.25	6.25	Sized for the WAS Flow from Secondary clarifiers at Maximum Month Flow (6.25 mgd)
Sludge Holding Tank	days	2	2	Sized for total sludge flow from Primary and Secondary Clarifiers at Max Month Flow (6.25 mgd)
Anaerobic Digestion	Hydraulic residence time (HRT days)	18	18	This is for average annual conditions
Dewatering Centrifuge	gpm	12	13	Sized based on solids produced from Anaerobic Digestion at Maximum Month Flows

gpd=gallons per day; sf=square feet; gpm=gallons per minute

## Appendix B. Greenhouse Gas Emissions Calculation Assumptions

The steady state mass balance results were used to calculate GHG emissions. The assumptions used to convert between energy demand, chemical demand and production, as well as biologically-mediated gases (i.e., CH<sub>4</sub> and N<sub>2</sub>O) and GHG emissions are provided in Table B-1. Methane and nitrous oxide emissions are included as they are thought to dominate direct carbon footprint emissions from wastewater treatment plants (Valkova et al., 2021). The assumptions are based on EPA (2020) values for energy production, the latest monitoring trends on N<sub>2</sub>O emissions (Valkova et al., 2021), Intergovernmental Panel on Climate Change (IPCC) (2006; 2013; 2019) for conversions and fugitive CH<sub>4</sub> emissions, and various resources for chemical production and hauling from production to the wastewater treatment plant (WWTP). N<sub>2</sub>O emissions benchmarking in wastewater is hindered by non-standard reporting (Vasilaki et al, 2019). Rather than rely on theoretical methods, data from on-site N<sub>2</sub>O measurements was used (Valkova et al., 2021). While there is more confidence in the data for on-site measurements, this is an area with potential for considerable variability from plant to plant as the on-site data measurements is limited. The data collected to date suggests that N<sub>2</sub>O emissions potential is inversely related to total nitrogen load reduction across the treatment plant. Additionally, the biogas produced during anaerobic digestion that is used as a fuel source is converted to energy with MOP8 (WEF 2009) recommended waste-to-energy values.

**Table B-1. Greenhouse Gas Emissions Assumptions**

Parameters	Units	Value	Source
N <sub>2</sub> O to CO <sub>2</sub> Conversion	lb CO <sub>2</sub> /lb N <sub>2</sub> O	265	IPCC, 2013
CH <sub>4</sub> to CO <sub>2</sub> Conversion	lb CO <sub>2</sub> /lb CH <sub>4</sub>	28	IPCC, 2013
Energy Production			
CO <sub>2</sub>	lb CO <sub>2</sub> /MWh	211.9	USEPA (2020)
N <sub>2</sub> O	lb N <sub>2</sub> O/MWh	0.003	USEPA (2020)
CH <sub>4</sub>	lb CO <sub>2</sub> /MWh	0.020	USEPA (2020)
Sum Energy Production	lb CO <sub>2</sub> /MWh	213.3	USEPA (2020)
GHGs per BTU Natural Gas			
CO <sub>2</sub>	lb CO <sub>2</sub> /MMBTU Natural Gas	117	USEPA (2014)
N <sub>2</sub> O	lb N <sub>2</sub> O/MMBTU Natural Gas	0.0002	USEPA (2014)
CH <sub>4</sub>	lb CH <sub>4</sub> /MMBTU Natural Gas	0.0022	USEPA (2014)
Sum Natural Gas	lb CO <sub>2</sub> /MMBTU Natural Gas	117.1	USEPA (2014)





Parameters	Units	Value	Source
Non-BNR N <sub>2</sub> O Emissions	% Mass N <sub>2</sub> O/ Mass influent Total Nitrogen	1.4%	Valkova et al. (2021)
BNR N <sub>2</sub> O Emissions	% Mass N <sub>2</sub> O/ Mass influent Total Nitrogen	1.0%	Valkova et al. (2021)
CH <sub>4</sub> Emissions (from Liquid Stream; excludes digestion)	g CH <sub>4</sub> /g BOD	0.03	IPCC (2019)
Biogas Purity	% Methane	65	WEF, 2009
Biogas to Energy	BTU/cf CH <sub>4</sub>	550	WEF, 2009
Digester Gas to Electrical Energy Transfer Efficiency	%	32	HDR Data
Chemical Production			
Alum	lb CO <sub>2</sub> /lb Alum	0.28	SimaPro 6.0 - BUWAL250, Eco-indicator 95
Polymer	lb CO <sub>2</sub> /lb Polymer	1.18	Owen (1982)
Sodium Hypochlorite	lb CO <sub>2</sub> /lb Sodium Hypochlorite	1.07	Owen (1982)
Sodium Bisulfite	lb CO <sub>2</sub> /lb Sodium Bisulfite	1.19	City of Winnipeg (2012)
Hydrogen Peroxide	lb CO <sub>2</sub> /lb Hydrogen Peroxide	1.19	USEPA (2017)
Building Energy Efficiency	kBTU/sf/yr	62	Median for the various listed buildings (Energy Star (2021))
Hauling Distance		-	
Local	miles	100	-
Hauling Emissions			
Fuel Efficiency	miles per gallon	8	
CO <sub>2</sub>	kg CO <sub>2</sub> /gal diesel	10.2	CA Climate Action Registry Reporting Tool (2008)
N <sub>2</sub> O	kg N <sub>2</sub> O/gal diesel	0.0001	CA Climate Action Registry Reporting Tool (2008)
CH <sub>4</sub>	kg CH <sub>4</sub> /gal diesel	0.003	CA Climate Action Registry Reporting Tool (2008)
Sum Hauling Fuel	kg CO <sub>2</sub> /gal diesel	10.2	CA Climate Action Registry Reporting Tool (2008)

GWh = Giga Watt Hours



MWh = Mega Watt Hours

MMBTU = Million British Thermal Units

BTU = British Thermal Unit

PE = Population Equivalents

kBTU/sf/yr = 1,000 British Thermal Units per Square Foot per Year

cf = cubic feet

lb = pound

kg = kilogram

gal = gallon



*This page is intentionally left blank.*